

Instruction manual

Contents

1. Intended use	5
2. Technical specifications	5
Control panel for boilers with ventilator	6
Control panel for boiler DC15E	6
Advantages of boilers	7
3. Technical data	8
Boiler drawings key	9
Technical data	9
Drawings of boilers	10
Extraction ventilator schematics	12
4. Type and seating of shaped pieces into combustion area	12
5. Boiler accessories	13
6. Fuel	14
Basic wood burning data	14
7. Boiler bases	15
8. Environment type and boiler placement in a boiler room	15
9. Chimney	15
10. Flue-gas duct	16
11. Fire prevention during installation and use of heating appliances	17
12. Connecting boilers to the electrical power network	18
13. Wiring diagram of electromechanical regulation with extraction ventilator, type UCJ 4C52 (DC18S - DC50S), (DC30SE - DC50SE), (DCxxSX), (DCxxGS) and with pressure ventilator (DC80, DC70S), valid from 12/2007	19
14. Wiring diagram for DC75SE - electromechanical regulation with an UCJ 4C52 type extraction ventilator, valid from 12/2007	20
15. Wiring diagram of electromechanical regulation of the DC15E type boiler, valid from 12/2007	21
16. Obligatory CSN EN standards dealing with boiler designing and boiler assembly	21
17. Choice and connection method of control and heating elements	22
18. Boiler corrosion protection	23
19. Specified basic boiler connection with Laddomat 22	23
20. Specified basic boiler connection with thermoregulation valve	24
21. Boiler connection with buffer tank and controlled three-way mixing valve	24
22. Recommended wiring diagram with Laddomat 22 and accumulation tanks	25
23. Laddomat 22	26
24. Thermoregulatory valve	26
25. Operating a system with accumulation tanks	27
The standard ATMOS accumulation tanks provided	27
Tank insulation	27
Advantages	27
26. Connection of overheat protecting cooling loop with a safety valve Honeywell TS 131 - 3/4 ZA or WATTS STS20	28
27. Operating instructions	28
Preparing boilers for operation	28
Ignition and operation	28
Waste gas thermostat setting	29
Output regulation - electromechanical	29
Draught regulator - HONEYWELL Braukmann FR 124 – Assembly instructions	30
28. Boiler output and combustion setting	31
For boilers DCxxS(X), DCxxGS with exhaust fan - version A	31
For boilers DCxxS/SX/SE, DCxxGS with exhaust fan - version B	31
For boiler DC70S with blower fan	32
29. Fuel refill	32
30. Steady heat operation	33
31. Boiler cleaning	33
Ceramic ash areas	35
32. Heating system maintenance - including boilers	36
33. Use and inspections	37
34. Possible failures and troubleshooting	37
35. Spares	38
Heatproof shaped piece (nozzle) replacement	38
Door sealing cord replacement	39
Adjusting the door hinges and locks	39
36. Environmental protection	39
Disposal of the boiler after expiration of its service life	39
GUARANTEE CONDITIONS	40
BOILER INSTALLATION REPORT	41
ANNUAL INSPECTIONS RECORDS	42
RECORDS OF GUARANTEE PERIOD AND POST-GUARANTEE PERIOD REPAIRS	43

WE HOPE YOU WILL BE SATISFIED WITH OUR PRODUCT, AND WE RECOMMENDED TO COMPLY WITH THESE MAIN REGULATIONS NECESSARY FOR LONG SERVICE LIFE AND CORRECT FUNCTION OF THE BOILER

EN

1. Assembly, firing-up test and operator's training **must be carried out by an installation company trained by the manufacturer**; this company also fills in a boiler installation report (p.41).
2. During the **gasification process, wood tar and condensates (acids)** form in the fuel stoking chamber. Therefore, there must be a thermoregulatory valve (Laddomat 22) installed behind the boiler in order to keep the **minimal temperature of water returning to the boiler at 65 °C**.

Operating temperature of water in the boiler must be in the **80 - 90 °C** range.

3. Every circulating pump in the system must be regulated by an individual thermostat in order to keep the **specified minimum temperature of water returning to the boiler**.
4. The boiler **must not be permanently** operated in an output **lower than 50 %**.
5. The boiler operates environmentally-friendly at the nominal output level.
6. When operating the boiler in a **lower output mode** (summer operation or heating up warm service water), it is **necessary to fire-up daily**.
7. We therefore recommend installing the boiler with **accumulation tanks, which provides 20 - 30 % fuel consumption decrease, and longer service life of both – the boiler and the chimney and user-friendlier operation**.
8. If you cannot install the boiler into an accumulation system, then we recommend installing it at least with **one equalising tank**; the volume of which should be 25 l per 1 kW of the boiler output.
9. Use only dry fuel with **12 - 20 % moisture content – higher moisture content decreases the boiler's performance and increases consumption**.

Boilers with an extraction ventilator are marked with S (DC 70S excluded) at the end of the label.



CAUTION – if the boiler is installed with a TV 60 °C (65/70/72/77 °C) thermoregulatory valve or Laddomat 22 and with the accumulation tanks (see attached schematics), the guarantee period for the boiler drum is extended from 24 to 36 months. The guarantee period for other parts remains unaffected. In non-compliance with these instructions the drum's and the heatproof pipes' service life may dramatically decrease. The boiler drum may corrode in as little time as 2 years.



CAUTION - INSTALLER SHOULD ALWAYS COMPLY WITH LOCAL PLANNING AND BUILDING REQUIREMENTS.

1. Intended use

The environmentally friendly boilers ATMOS DC 15/18/20/22/25/30/32/40/50/70/75 are designed for heating family houses, cottages, holiday houses and other similar buildings. Boilers are suitable for buildings with heat loss ranging between 15 - 75 kW, depending on type. The boilers are constructed mainly for burning logs. Any type of dry wood is suitable for heating, especially wooden logs up to a maximum length 250, 330, 530, 730 and 1000 mm as per the boiler type. If you use logs of a larger diameter the nominal output is then decreased and the burning period prolonged. The boiler is not intended for burning saw dust or small-particle wood waste. These can be burnt in small quantities only, together with log-firewood. MAX.10 %. Due to their huge feeding hoppers, the boilers save the user a lot of laborious wood wood preparation and splitting operations. They save both - the physical effort and also the time dedicated to these operations.

2. Technical specifications

The boilers are designed for burning wood based on generator gasification principle utilising an extraction ventilator (DC15E excluded), which extracts the waste gas from the boiler or blows the air in the boiler.

- | | |
|------------------------|---|
| a) exhaust fan | – for boilers DC18S, DC22S, DC25S, DC30SE, DC32S, DC50S, DC40SE, DC50SE, DC75SE, DC15GS, DC20GS, DC25GS, DC32GS, DC40GS, DC22SX, DC30SX, DC40SX |
| b) pressure fan | – for DC70S (DC80) |
| c) without fan | – DC15E |

The boiler drum is manufactured as a welded structure from 3 - 8 mm thick steel sheets. The top comprises the Fuel Hopper and the lower end of this hopper comprises a heatproof shaped piece with longitudinal opening for combustion remnants and gases. The burn-off chamber is equipped with ceramic shaped pieces. There is a vertical waste gas duct at the rear of the boiler body which is in its upper section equipped with an ignition valve. The upper part of the waste gas duct is equipped with gas outlet pipe for connecting to chimney. The front wall is in the upper part equipped with stoking door and with ashtray door in the lower part. In the front section of the upper hood there is an ignition valve pull rod. The boilers' drum is externally heat insulated with mineral wool placed beneath the sheet metal covers of the boilers' external housing. A control panel for electromechanical regulation is situated in the upper part of the boiler. In the rear section of the boilers, there is a primary and secondary air feeding duct fitted with a control valve, which is operated by FR 124 draught regulator. Primary and secondary air is preheated to high temperature. For boilers DC50SE, the valve with the FR 124 draught regulator is replaced with servo drive with inbuilt spring. This boiler also contains two special steel plates alongside the gasifying nozzle.

Control panel for boilers with ventilator

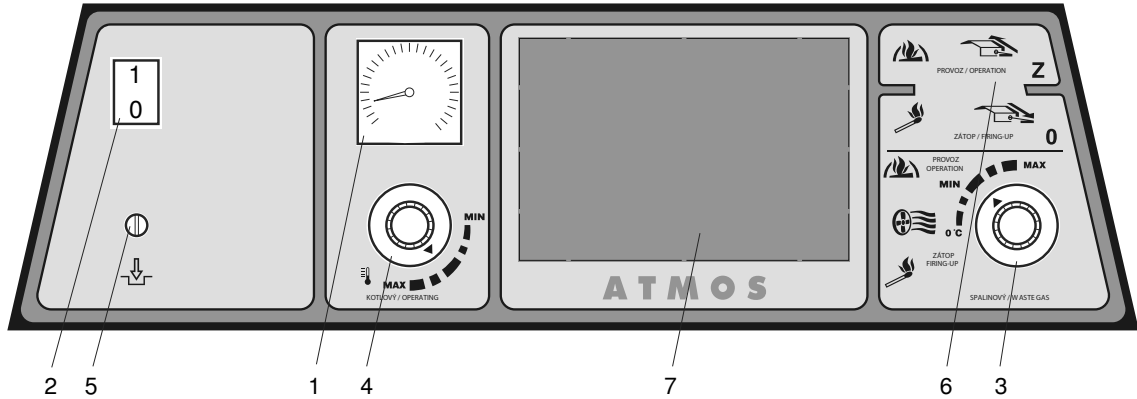

Control panel for boiler DC15E

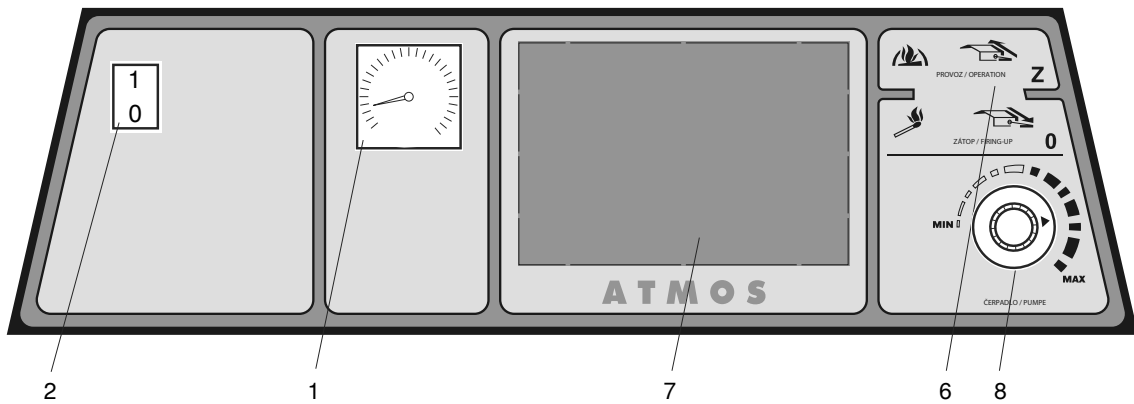

- | | |
|-----------------------------------|---|
| 1. Thermometer | 6. Ignition valve pulling rod |
| 2. Main switch | 7. Area for electronic regulation of the heating system (92x138 mm) |
| 3. Waste gas thermostat | 8. Pump thermostat (only DC15E) |
| 4. Control thermostat (boiler) | |
| 5. Safety irreversible thermostat | |

Description:

1. **Thermometer** – monitors the temperature of water exiting the boiler.
2. **Main switch** – allows for completely shutting down boiler if necessary.
3. **Waste gas thermostat** – is used to switch off the ventilator when the fuel has burnt out.



CAUTION – when firing up (igniting), set the waste gas thermostat to (“0 °C“ - firing-up). After flaring up, set the waste gas thermostat to „operation“. It is necessary to detect the optimal operating position. Should the waste gas temperature fall below the preset value, the thermostat switches the extraction ventilator off. If you want the ventilator to re-start, set a lower temperature on the waste gas thermostat (set to “0 °C“ - firing-up).

4. **Control thermostat (boiler)** – controls the boiler operation depending on the temperature of water exiting the boiler.
5. **Safety irreversible thermostat** – serves as boiler protection against overheating in case of control thermostat failure or as an indication of exceeding the emergency temperature. **If such exceeding occurs, it is then necessary to depress the thermostat.**
6. **Ignition valve pulling rod** – serves for opening the ignition valve during heating or inserting fuel.
7. Area for electronic regulation of the heating system can be used to house any type of regulation system that fits into an aperture of (92x138 mm). The electric harness is prefabricated and ready to be used for the regulation’s power supply.
8. Pump thermostat in the DC15E boiler for switching the pump in the boiler circle (75 - 80 °C)

Advantages of boilers

Boilers provide burning at high temperatures with the generator gasification function. That results in fuel saving and ecological operation. The boilers pre-heat the primary and secondary air to a high temperature which results in warm and stable flame of stable burning quality. Boilers marked with GS provide this process in the ceramic combustion area with primary air side inlets. Boilers equipped with extraction ventilator require simple and easy operation, and are marked with “S” (DC70S, DC15E excluded). Large fuel hopper allows burning of the log pieces with the maximum length 250 - 1.000 mm, depending on the boiler type. Large pieces of waste wood can also be burned. All boilers are equipped with cooling loop for overheating protection.

3. Technical data

ATMOS boiler type	DC15E	DC18S	DC22S	DC22SX	DC25S	DC30SX	DC32S DC30SE	DC40SX	DC15GS	DC20GS	DC25GS DC32GS	DC40GS	DC50S	DC50SE	DC70S DC80	DC75SE	
	Boiler output	kW	14,9	20	22	22	25/27	30	35 30	40	15	20	25 32	40	49,9	40	70
Heat-up area	m ²	1,8	1,8	2,1	1,9	2,3	2,3	2,9	2,9	1,8	2	2,7 2,9	3,2	3,8	4,2	5	5,2
Fuel duct volume	dm ³	66	66	100	66	100	100	140	140	66	80	120/25	160	180	252	180	345
Feeding inlet dimensions	mm	450x260	450x260	450x260	450x260	450x260	450x260	450x260	450x260	450x260	450x260	450x260	450x260	450x260	450x260	450x260	450x315
Specified chimney draught	Pa	18	20	23	23	24	24	24	25	16	20	23/24	25	25	25	30	30
Max. water overpressure	kPa	250	250	250	250	250	250	250	250	250	250	250	250	250	250	250	250
Boiler weight	kg	260	269	324	290	326	332	366/400	368	302	343	431/436	485	443	545	515	669
Gas-outlet pipe diameter	mm	150/152	150/152	150/152	150/152	150/152	150/152	150/152	150/152	150/152	150/152	150/152	150/152	150/152	150/152	180	180
Boiler height	mm	1185	1185	1185	1185	1185	1185	1260	1260	1280	1280	1434	1260	1260	1360	1399	1487
Boiler width	mm	675*	675*	675*	675*	675*	675*	678	678	678	678	678	774	774	678	774	774
Boiler depth	mm	758	758	959	758	959	959	959	959	670	758	959	1160	1160	1160	1166	1487
Electric parts ingress protection	IP	20															
Electric input	W	0	50	50	50	50	50	50	50	50	50	50	50	50	50	50	70
Boiler effectiveness	%	80,4	83,3	85,4	83,3	89,9	89,9	88,9 86,6	88,9	91,2	> 89	88,8 89,3	87,7	81	86,3	82,5	82,5
Boiler class		3	4	4	4	5	5	5/4	5	5	5	5	4	3	4/3	3	3
Energy efficiency class		A+	A+	A+	A+	A+	A+	A+	A+	A+	A+	A+	A+	A+	A+	A+	A+
Waste gas temperature at nominal output	°C	208	206	216	206	177	177	188/207	185	134	166	173/171	245	255	245	245	233
Waste gas combustion products flow weight at nominal output	kg/s	0,010	0,012	0,014	0,014	0,015	0,017	0,017	0,022	0,010	0,012	0,022	0,025	0,025	0,035	0,035	0,035
Specified fuel (preferred)		Dry wood with heating capacity 15 - 17 MJ.kg ⁻¹ , water content at least 12 % - max. 20 %, average 80 - 150 mm															
Average fuel consumption	kg.h ⁻¹	3,5	3,8	5	5	6	7	7,2/7	10	3,5	3,8	6/7,2	10	13	13	18	18
Per heating season		1 kW = 1 stacked cubic meter															
Maximum wood length	mm	330	330	530	330	530	530	530	530	250	330	530	530	730	700	730	1000
Burning time at nominal output	hod.	2	2	3	2	3	2	3	2	2	2	3/2	3	3	3	2	3
Boiler water volume	l	45	45	58	45	58	58	80	80	56	64	80	90	110	141	93	171
Hydraulic pressure drop	mbar	0,18	0,18	0,21	0,18	0,21	0,21	0,20	0,20	0,20	0,22	0,23	0,22	0,22	0,23	0,25	0,24
Equalising tank minimum volume	l	500	500	500	500	500	500	500	500	500	500	750	750	750	750	1000	1000
Connecting voltage	V/Hz	230/50															
Specified minimum temperature of water returning to boiler is 65 °C when in operation.																	
Specified boiler operating temperature is 80 - 90 °C.																	

* boiler width is 555 mm after disassembling the side hoods

Boiler drawings key

- | | |
|--|---|
| <ol style="list-style-type: none"> 1. Boiler drum 2. Stoking door - upper 3. Ash-pan door - bottom 4. Ventilator - pressure
- extraction (exhaust fan) 5. Heatproof shaped piece - nozzle 6. Control panel 7. Safety thermostat for pump - 95°C (only for DC75SE) 8. Control valve 9. Heat proof shaped piece – for type GS
- combustion area side 10. Heat proof shaped piece – for type GS
- spherical space 11. Nozzle sealing - 12x12 (14x14) 12. Heatproof shaped piece – half moon 13. Ignition valve 14. Heat proof shaped piece – for type GS
- rear head of spherical space 15. Cleaning lid 17. Ignition valve pulling rod 18. Thermometer 19. Frame screen 20. Switch with an indicator light 22. Draught regulator - Honeywell FR 124 23. Cooling loop protecting against overheating 24. Ventilator control thermostat (boiler) | <ol style="list-style-type: none"> 25. Door filling - Sibrál 26. Door sealing – cord 18x18 27. Ceramics - roof 28. Switching thermostat for pump - (only for DC75SE) 29. Capacitator for exhaust fan - 1µF 31. Heatproof shaped piece – half moon 32. Heatproof shaped piece – combustion area plate 33. Waste gas brake for rear flue way duct 34. Cleaning aperture (DC70S) 35. Waste gas thermostat 36. Safety thermostat (Caution – in overheat condition must be depressed) 37. Waste gas brake - under the roof
(only for DC30SX, DC40SX, DC50S, DC75SE) 38. Stoking chamber lining – for DC15E 40. Pump thermostat for DC15E 41. Combustion area screen - rear (model DCxxSE) 42. Primary air regulation 43. Secondary air regulation <p style="margin-top: 10px;"> K - flue gas duct neck
 L - water outlet from
 M - boiler – water inlet to
 N - boiler – filling valve
 P - pipe sleeve – sleeve for cooling loop control valve sensor (TS 131, STS 20) </p> |
|--|---|

Technical data

	DC15E DC18S	DC22SX	DC22S DC25S	DC30SX	DC32S DC30SE	DC40SX	DC15GS	DC20GS	DC25GS	DC32GS	DC40GS	DC40SE	DC50SE	DC50S	DC70S DC 80	DC75SE
A	1185	1185	1185	1185	1260	1260	1280	1280	1280	1280	1434	1360	1360	1260	1399	1487
B	694 758	758	959	959	959	959	670	758	959	959	959	961	1160	1160	1166	1487
C	675*	675*	675*	675*	678	678	678	678	678	678	678	774	774	678	678	774
D	690 874	874	874	874	950	950	950	950	950	950	1099	1046	1046	950	1047	1165
E	150/152	150/152	150/152	150/152	150/152	150/152	150/152	150/152	150/152	150/152	150/152	150/152	150/152	150/152	180	180
F	65	65	65	65	69	69	69	69	69	69	69	69	69	69	90	82
G	208	208	208	208	185	185	185	185	185	185	185	185	185	185	325	194
H	933	933	933	933	1008	1008	1008	1008	1008	1008	1152	1106	1106	1106	423	1230
CH	212	212	212	212	256	256	256	256	256	256	256	306	306	256	0	306
I	212	212	212	212	256	256	256	256	256	256	256	306	306	256	240	306
J	6/4"	6/4"	6/4"	6/4"	6/4"	6/4"	6/4"	6/4"	6/4"	6/4"	2"	2"	2"	2"	2"	2"

* boiler width is 555 mm after disassembling the side hoods

Drawings of boilers

EN

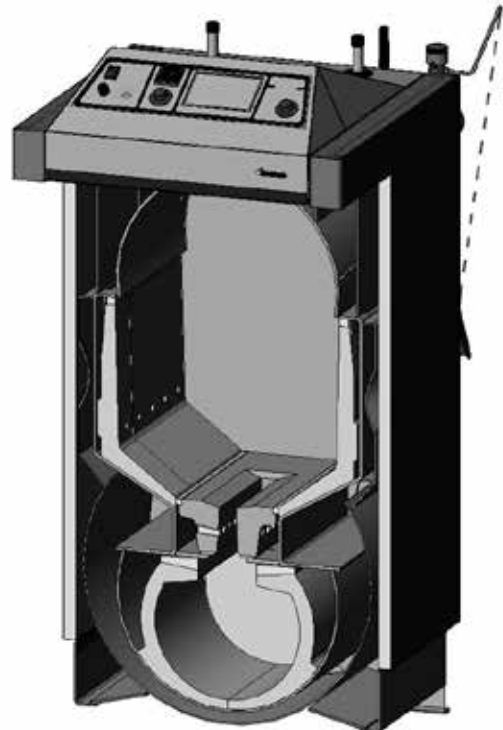
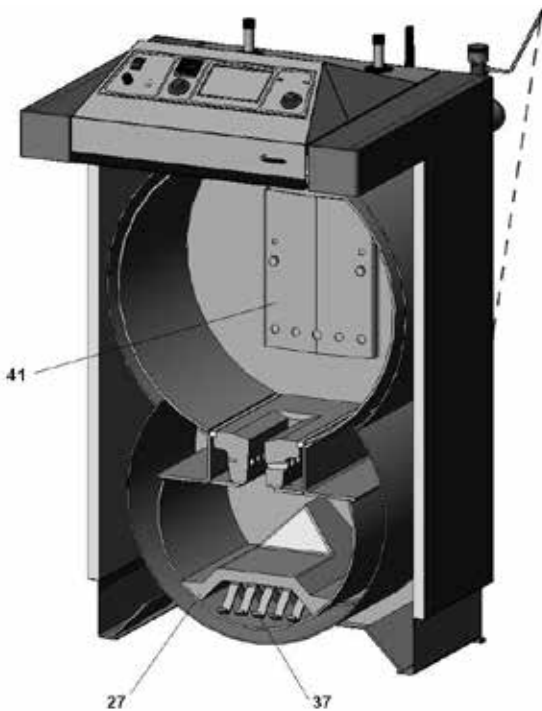
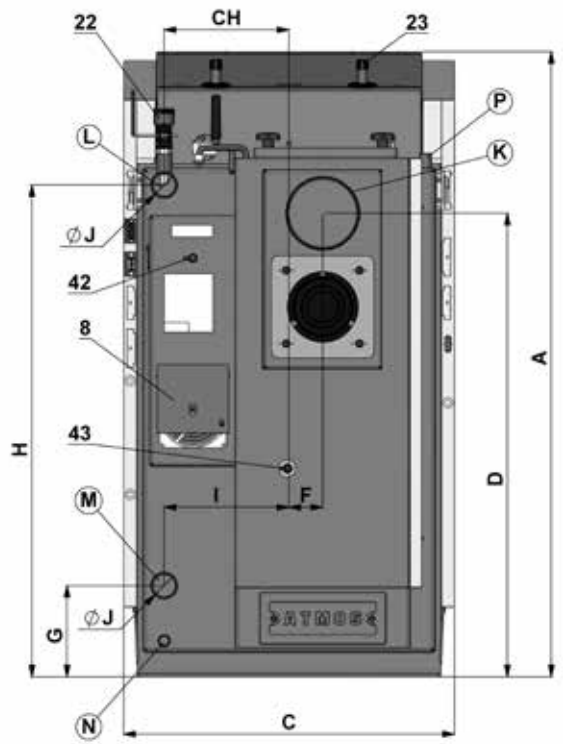
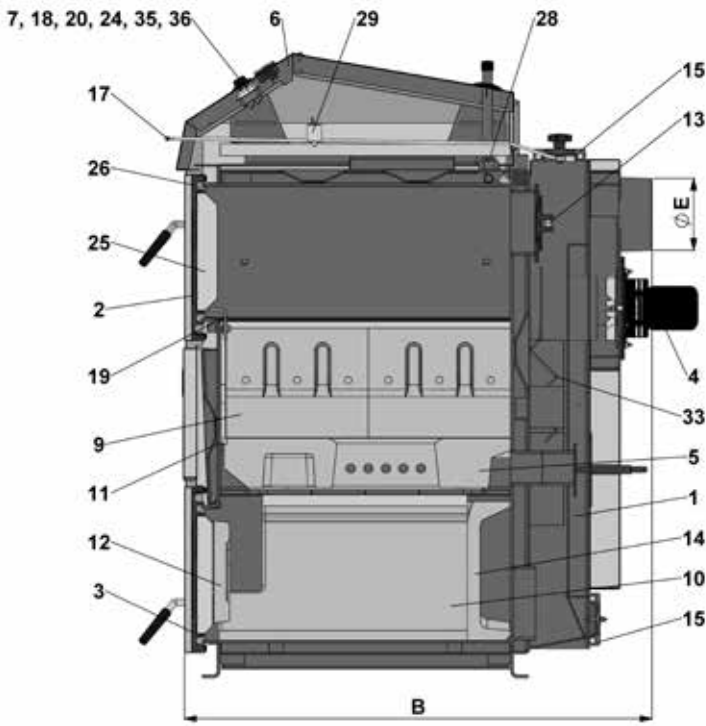

Drawing of boiler DC70S

Cut away view - DC15E

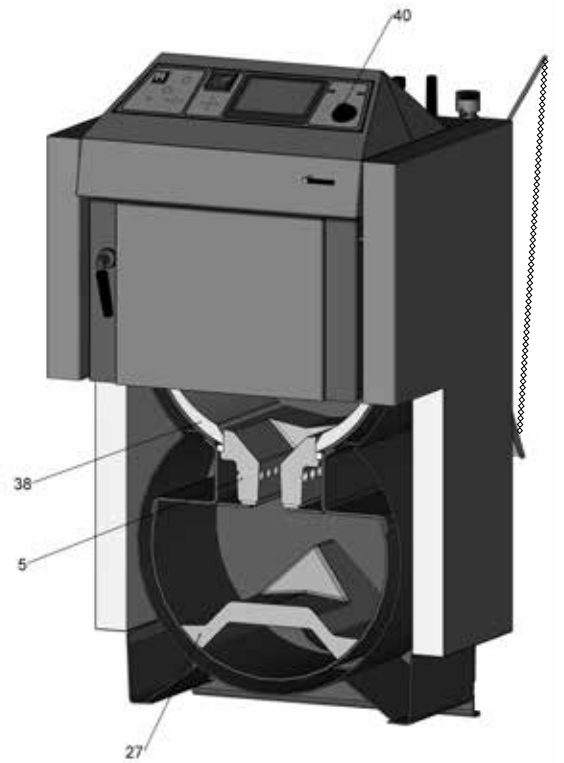
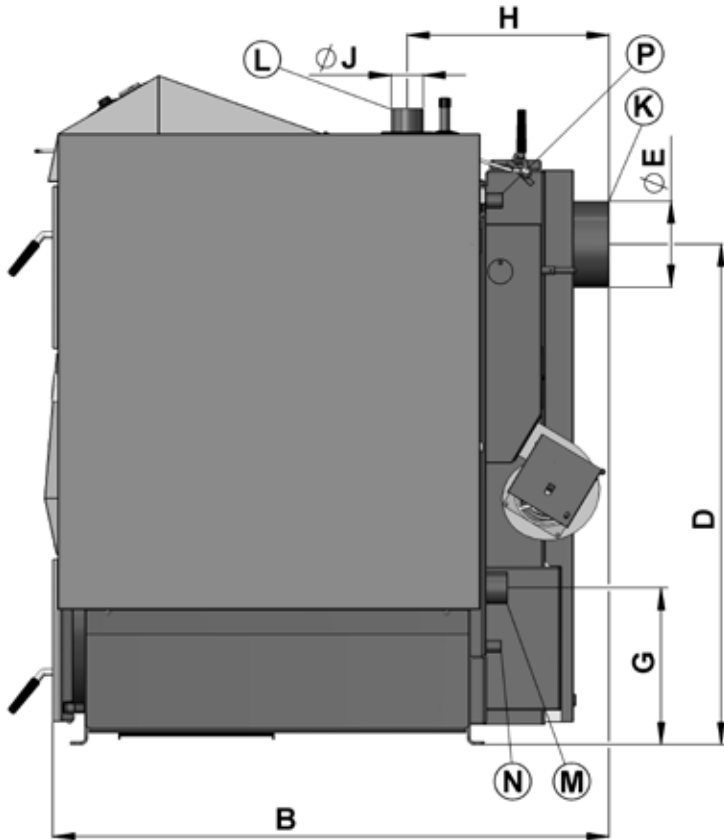

EN

Cut away view – DC70S

Combustion chamber

- 3. Ash-pan door
- 5. Heatproof shaped piece - nozzle
- 31. Heatproof shaped piece – half moon
- 32. Heatproof shaped piece – combustion area plate.
- 34. Cleaning aperture

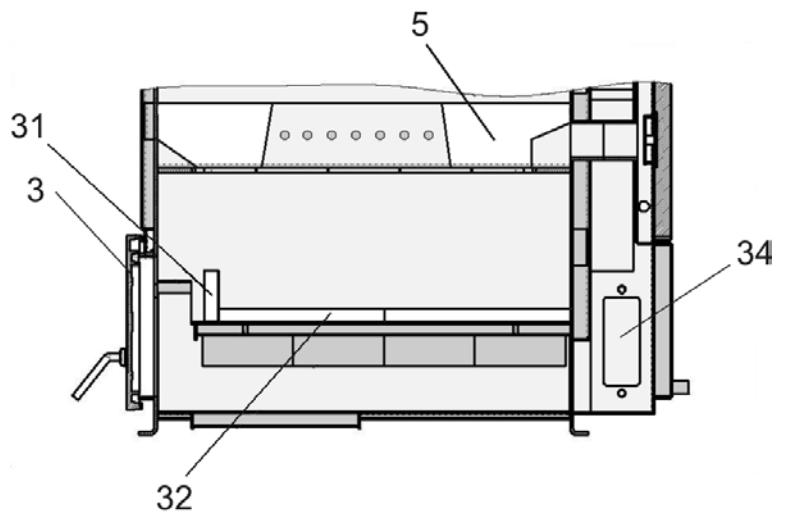

Extraction ventilator schematics



CAUTION – The exhaust ventilator (S) is provided disassembled. Place it on the smoke duct, fasten properly and test its smooth operation

EN

- 1 - Motor
- 2 - Plate
- 3 - Rotating wheel (stainless steel)
- 4 - **Nut with left-handed thread** and washer
- 5 - Wing nut
- 6 - Screw
- 7 - Large gasket (2 pcs)
- 8 - Small gasket

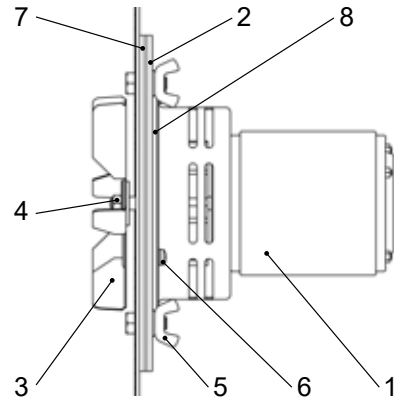

4. Type and seating of shaped pieces into combustion area

1. For type

DC15E
DC18S
DC22S
DC25S
DC30SX
DC32S
DC50S
DC40SE
DC40SX
DC50SE

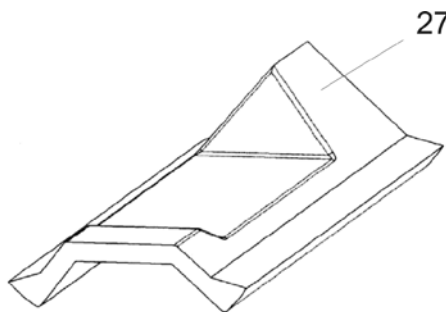

27. Heatproof shaped piece – roof is for:

- for boiler (DC15E, DC18S) length 320 mm

- for boilers (DC22S, DC25S, DC30SX, DC32S, DC40SE, DC40SX) length 500 mm;

- for boilers (DC50S, DC50SE) length 700 mm.



Roof of the lower combustion area must always be fully pressed against the boiler rear wall.

2. For type

DC75SE

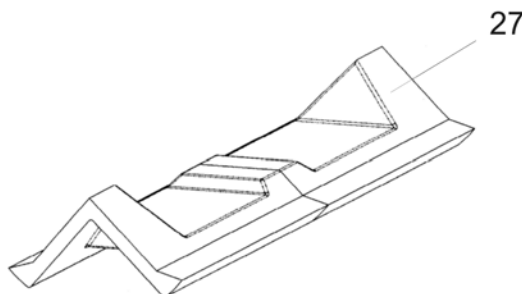

Roof for this boiler type consist of two pieces – see figure (DC75SE – 2 x 500mm)

3. For type

- DC18S
- DC15GS
- DC20GS
- DC22SX
- DC25GS
- DC30SE
- DC32GS
- DC40GS

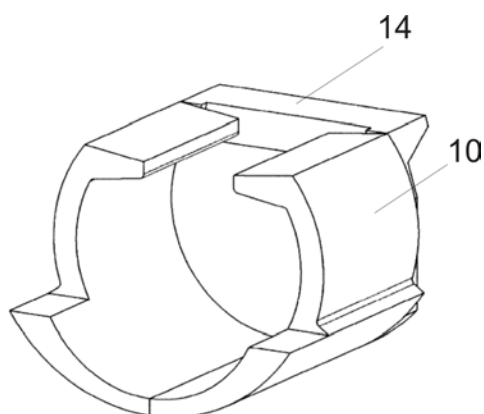

- 10. Heatproof shaped piece - Spherical space (L+R side),
- 14. Heatproof shaped piece - rear face with a rearward recess

The spherical space must be assembled in a way that ensures that the front section of the piece /10/ is 3 cm away from the front edge of the boiler frame.



CAUTION – do not turn the rear face /14/ when handling

4. For type

- DC15E

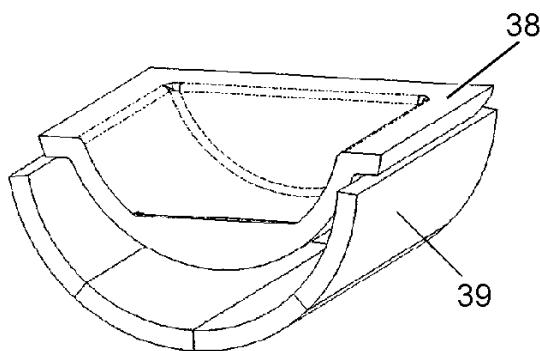

- 38. Spherical area
- 39. Combustion area lining (2 x 2 piece)

Spherical area /38/ must be pushed to the rear of combustion area

5. For type

- DC70S

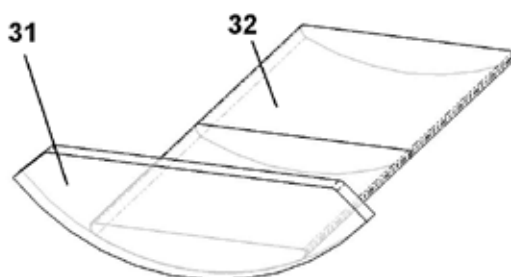

- 31. Heatproof shaped piece – half moon.
- 32. Heatproof shaped piece – combustion area plate (2 pieces)



Front shaped piece is removed during boiler clean-up. It is positioned on the front side of the combustion chamber towards the door.

5. Boiler accessories

- Steel brush with accessories 1 pc
- Poker 1 pc
- Filling-in valve 1 pc
- Operating and maintenance instructions manual 1 pc
- Draught regulator - HONEYWELL FR 124 (DC50SE excluded) 1 pc
- Ashtray (only for DCxxGS) 1 pc

6. Fuel

Specified fuel is dry chopped log fire wood, Ø 80 - 150 mm, at least two years old, moisture 12 % to 20 %, caloric power 15 – 17 MJ.kg⁻¹ and log length 330 - 1000 mm as per boiler type. Fuel dimensions are stated in section 3 „Technical Data“. It is also possible to burn large pieces of wood waste in combination (max. 10 %) with crude logs.

Basic wood burning data

You can ensure maximum output and a long service life if you burn wood which has been left for at least 2 years to dry. The following graph illustrates the relationship of moisture content to heating capacity of the fuel. The energy content declines dramatically with increased water contents.

Example:

Wood with 20 % moisture contents has thermal power of 4 kWh / 1 kg of wood

Wood with 60 % moisture contents has thermal power of 1.5 kWh / 1 kg of wood

- Example – spruce wood which has been stored for 1 year under shelter – see graph

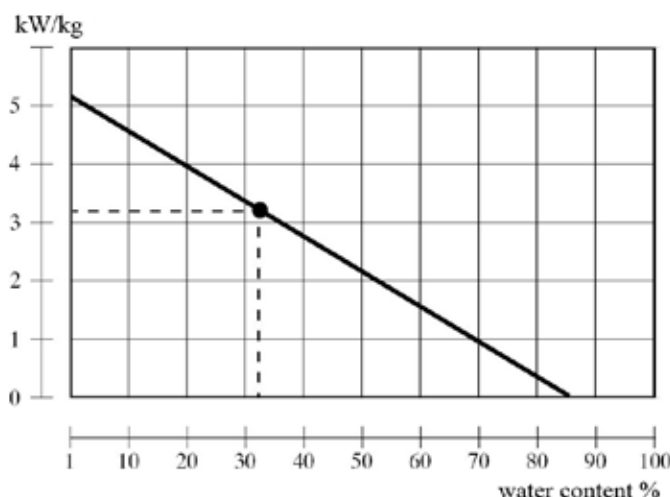

The boilers maximum output with wet fuel illustrated in the graph

	kW
DC 15 E	- 8
DC 18 S	- 13
DC 22 S	- 14
DC 25 S	- 19
DC 32 S	- 24
DC 40 S(E)	- 31
DC 50 S(E)	- 39
DC 75 S(E)	- 53

The information is relevant to other gasification boiler types.



Boilers are not suitable for burning wood with moisture content lower than 12 %.

Fuel heating capacity

Wood - type	Heating capacity per 1 kg		
	kcal	kJoule	kWh
spruce	3900	16250	4,5
pine	3800	15800	4,4
birch	3750	15500	4,3
oak	3600	15100	4,2
beech	3450	14400	4,0



Raw wood does not burn easily, produces a lot of smoke and substantially decreases the service life of your boiler and chimney. Boiler output drops as low as 50 % and fuel consumption doubles.

7. Boiler bases

Boiler type (mm)	A	B
DC15GS, DC15E/DC18S/ DC22SX	600	600
DC20GS	700	600
DC22S/DC25S/DC30SX	600	800
DC30SE/DC32S/DC25GS/ DC32GS/DC40GS/DC40SX	700	800
DC40SE	700	1000
DC50SE	800	1000
DC50S, DC70S	700	1000
DC75SE	800	1300

We recommend providing a concrete (metal) base under the boiler.

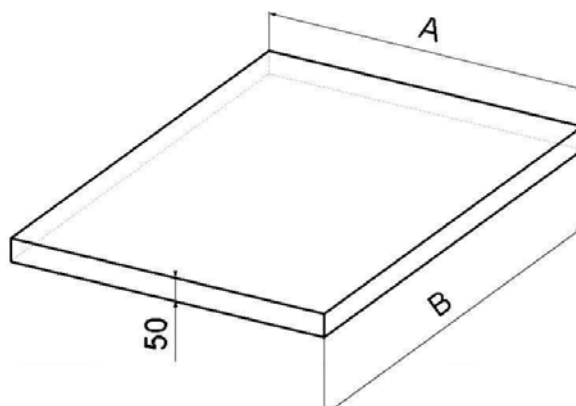

8. Environment type and boiler placement in a boiler room

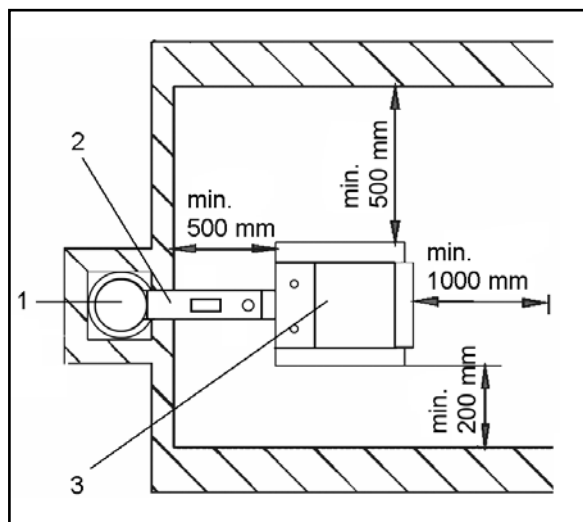

Boilers may be used in a “basic environment” - AA5/AB5 as specified in Czech standard ČSN3320001. Boilers must be placed in a boiler room with sufficient air access necessary for combustion. Placing boilers in living areas (including halls) is not permitted. The combustion air inlet aperture in the boiler room must be of minimum 300 cm² for boilers of 15 - 75 kW outputs.

- 1 - Chimney
- 2 - Flue duct
- 3 - Boiler

9. Chimney

Connecting the appliance to the chimney vent stack must always be carried out with the permission of the appropriate chimney authority. The vent stack must always be capable of providing sufficient draught and it must discharge the waste gas into the open atmosphere in a reliable manner for all possible operating conditions. The dimensions of the individual vent stack must be correct to ensure good functionality of the boiler; **because the draught influences combustion, performance and the service life of the boiler.** The chimney draught is directly dependent on its cross section, height and the inner wall ruggedness. It is not permitted to connect another appliance

into a chimney into which a boiler is connected. **The chimney diameter must not be smaller than the boiler outlet (min. 150 mm).** The chimney draught must comply with the specified values (see technical data, page 8). The chimney must not be excessively high, otherwise the boiler effectiveness is decreased and the combustion is affected (the flame “breaks”). In case of excessive draught, install a throttle valve in the flue gas duct between the boiler and the chimney.

Indicative values of the chimney cross section dimensions:

20 x 20 cm	height 7 m
Ø 20 cm	height 8 m
15 x 15 cm	height 11 m
Ø 16 cm	height 12 m

Exact chimney dimensions are stipulated in Czech standard ČSN 73 4201. Specified chimney draught is stated in section 3 „Technical Data“.

10. Flue-gas duct

The flue-gas duct must be connected into the chimney vent stack. If the boiler cannot be connected to the chimney directly, the appropriate flue-gas duct extension must be as short as possible in the given circumstances, but not longer than 1m, it must be without additional heating surface and must incline upwards in the direction towards the chimney. Flue-gas ducts must be mechanically durable and sealed against combustion products and gas penetration, and it must be possible to clean them inside. The flue-gas ducts must not be lead through another person's apartment or property. The internal diameter of the flue-gas duct must not be larger than the internal diameter of the chimney intake and it must not decrease in width in the direction towards the chimney. Use of elbow-pipes is not suitable. Methods for providing flue-gas duct entries through flammable material structures are stipulated in appendices 2 and 3 of the Czech standard ČSN 061008. These are appropriate for mobile installations, wooden cottages etc.

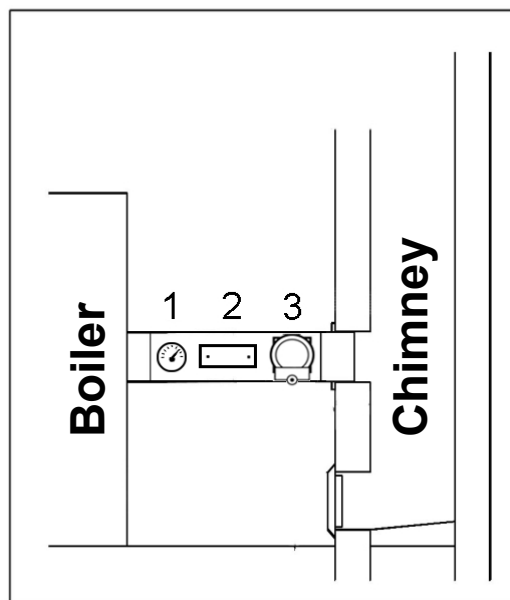

- 1 - Waste gas thermometer
- 2 - Cleaning aperture
- 3 - Draught regulator (limiter) / throttle valve



INFO - In case of excessive chimney draught, install draught regulator (limiter) /3/ or a throttle valve.

11. Fire prevention during installation and use of heating appliances

Selected from ČSN 061008 – Fire safety of local appliances and heat sources.

Safe distances

When installing the appliance, keep a minimum safe distance of 200 mm from building materials. This distance is valid for boilers and flue-gas ducts positioned near flammable materials of the B, C1 and C2 flammability class materials (the flammability classes are listed in chart 1). It is necessary to double the 200 mm safe distance if the boilers and flue-gas ducts are placed near flammable materials of C3 class (see chart 1). It is also necessary to double the safe distance if the flammability class of the material in question cannot be determined. The safe distance can be decreased to one half (to 100 mm) if a heat insulating, non-combustible screen (asbestos board) of a 5 mm minimum thickness, is placed 25 mm from the protected combustible material (so called flammable insulation). The screening board or protection screen (on the protected object) must exceed the boiler outline including its flue-gas duct on each side by at least 150 mm and by at least 300 mm above its upper surface. The screening board or protection screen must be also used for all fixtures and fittings from combustible materials in cases where the safe distance cannot be maintained (such as in mobile structures or wooden cottages etc. - for more details see ČSN 061008 standard). The safe distance must be maintained even when placing fixtures and fittings near the boilers.

If boilers are placed on floors from combustible materials, the floor must be fitted with a non-combustible, heat insulating pad exceeding the boiler's ground-outline on the side where the stoking and ash-pan apertures are, by at least 300 mm (in front of the aperture) and on all the other sides by at least 100 mm. The non-combustible, heat insulating pad can be made from any material of A flammability class.

Chart 1

Flammability classes of building materials and products	
A – non-combustible	granite, sandstone, concrete, bricks, ceramic tiles, mortars, fireproofing plasters etc.)
B – non-easily flammable	Akumin, Izomin, Heraklit, Lignos, basalt felt boards, fibreglass boards, Novodur
C1 – low degree of flammability	deciduous tree wood (oak, beech), Hobrex boards, plywood, Sirkolit, Werzalit, hardened paper (Formica), Ecrona)
C2 – medium degree of flammability	coniferous tree wood (pine tree, larch, spruce), chipboards and cork boards, rubber flooring (Industrial, Super)
C3 – high degree of flammability	fibreboards (Hobra, Sololak, Sololit), cellulose materials, polyurethane, polystyrene, polyethylene, foamed PVC



In circumstances when there is a risk of temporary access of flammable gases or fumes, or during works when a temporary fire or explosion risk may possibly occur (such as gluing linoleum, PVC etc.) the boilers must be put out of operation long enough before the risk occurrence. **No items from flammable materials may be placed on the boilers or near them for a distance lower than the specified safe distance (more see ČSN EN 13501-1).**

12. Connecting boilers to the electrical power network

The boilers are connected to 230 V, 50 Hz mains with a mains cable without a plug. The mains supply cable in case of repair it must be replaced with the same type by the servicing organization. Connection, maintenance and reparation can be made only by a qualified person in accordance with valid regulations of the particular country.



CAUTION - The mains cable must not be equipped with a plug (designed to be connected to a socket). It must be connected in a fixed way to a switchboard or junction box to avoid confusion of the conductors.

Mains cable must be regularly checked and maintained in the prescribed condition. It is forbidden to interfere in to the safety circuits and elements for safe and reliable operation of the boiler. If any damage of electrical equipment must be the boiler out of operation, disconnect from the mains and ensure a qualified repair according to applicable standards and regulations.

Connectors in side hoods of the boiler:



Connector in the right side hood

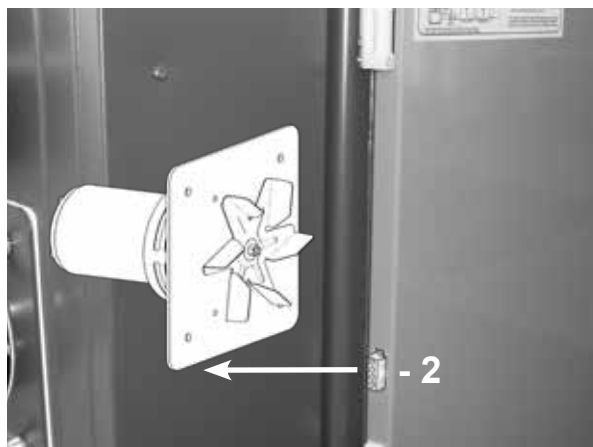

Connector in the left side hood

1 - connector for income cabel (L - brown, N - blue, PE - green/yellow)

2 - connector for extraction fan

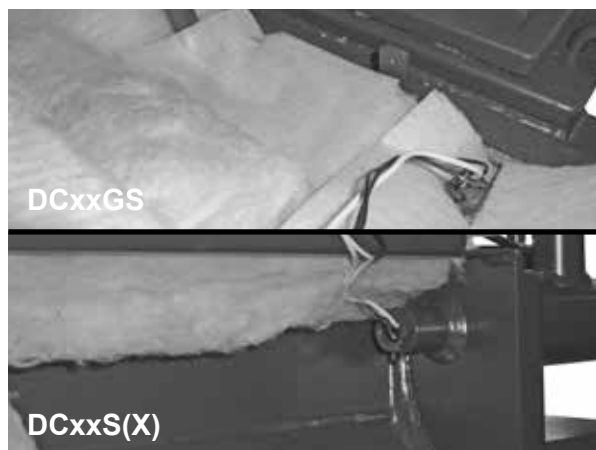

Pocket for thermostats (sensors)

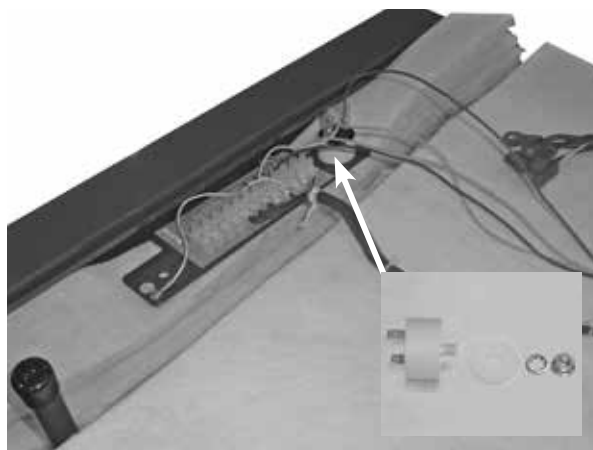

Capacitator for exhaust fan - 1 μ F

13. Wiring diagram of electromechanical regulation with extraction ventilator, type UCJ 4C52 (DC18S - DC50S), (DC30SE - DC50SE), (DCxxSX), (DCxxGS) and with pressure ventilator (DC80, DC70S), valid from 12/2007

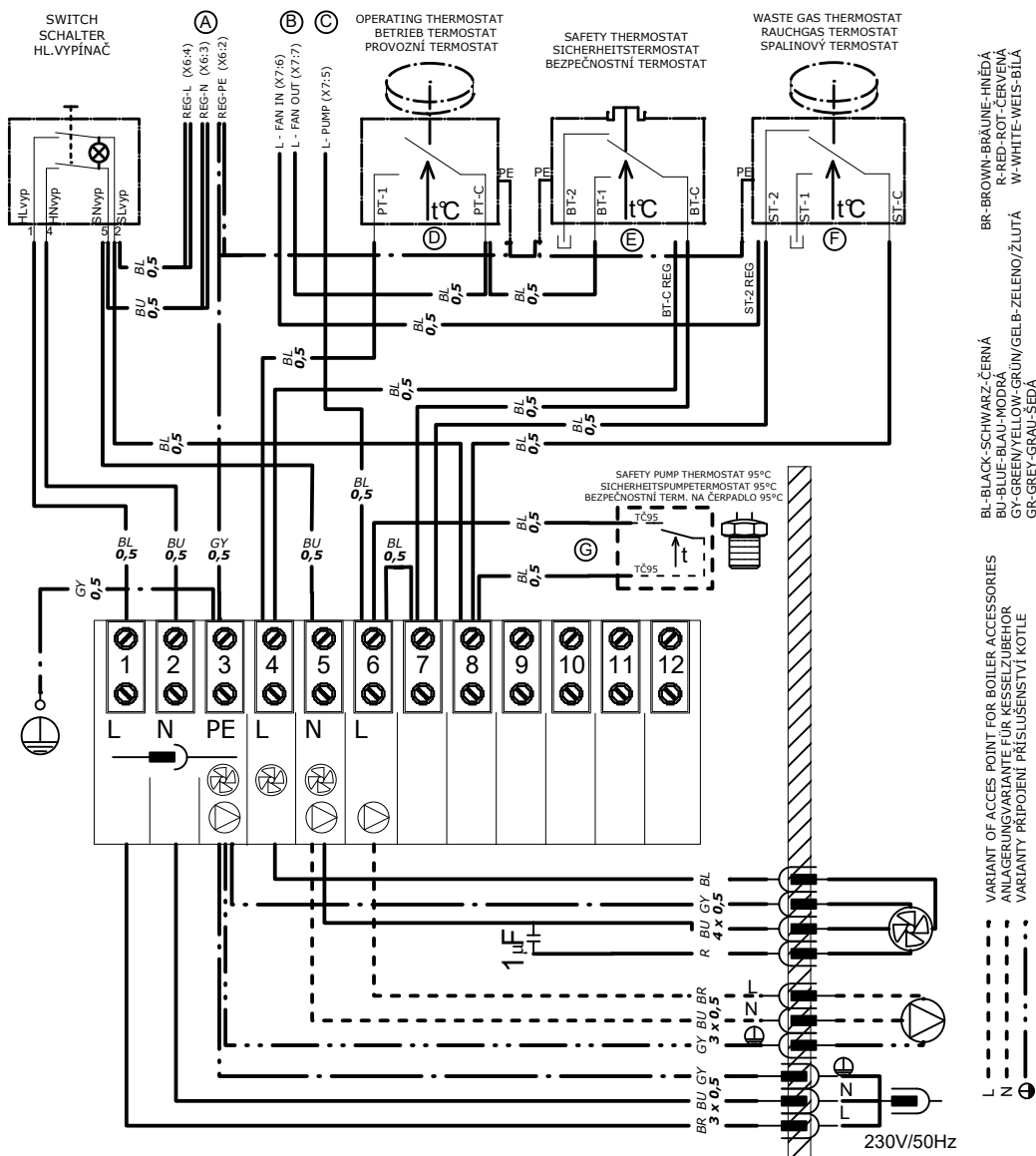

BR-BROWN-BRÄUNE-HNĚDÁ
 R-RED-ROT-CERVENÁ
 W-WHITE-WEISS-BILÁ
 BK-BLACK-SCHWARZ-CĚRNÁ
 BU-BLUE-BLAU-MODRÁ
 GY-GREEN/YELLOW-GRÜN/GELB-ZELENO/ŽLUTÁ
 GR-GRAY-GRAU-ŠEDÁ

VARIANT OF ACCESS POINT FOR BOILER ACCESSORIES
 ANLAGERÜCKSCHLÜSSEL FÜR KESSELZUBEHÖR
 VARIANTY PŘIPOJENÍ PŘÍSLUŠENSTVÍ KOTLE

WHEN USE ELECTRONIC REGULATION MUST BE THESE CHANGES OF WIRING:
 BEI DER STEUERUNG DES KESSELBETRIEBES DER ELEKTRONISCHE REGELUNG MÜSSEN DIESE ÄNDERUNGEN MACHEN SEIN:
 PŘI ZAPOJENÍ ELEKTRONICKÉ REGULACE PŘEVEDTE TYTO ZMĚNY:

- (A) VARIANTS OF RESERVOIR POINTS "REG L,N,PE" (FERRULE/FASTON 6,3) FOR ELECTRONIC REGULATION
 SPEISEKLEMMENVARIANTEN "REG L,N,PE" (ADERENDHÜLSE/FASTON 6,3) FÜR ELEKTRONISCHE REGELUNG
 VARIANTY NAPÁJECÍCH SVOREK "REG L,N,PE" (DUTINKA/FASTON 6,3) PRO ELEKTRONICKOU REGULACI
- (B) RESERVOIR POINT "L - FAN IN" AND "L - FAN OUT" OF BOILER FAN TO THE ELECTRONIC REGULATION
 SPEISEKLEMME "L - FAN IN" UND "L - FAN OUT" DER KESSELGEBLÄSE FÜR DIE ELEKTRONISCHE REGELUNG
 PŘIPOJOVACÍ SVORKA "L - FAN IN" A "L - FAN OUT" KOTLOVÉHO VENTILÁTORU DO ELEKTRONICKÉ REGULACE
- (C) RESERVOIR POINT "L-PUMP" OF BOILERPUMP TO THE ELECTRONIC REGULATION
 SPEISEKLEMME "L-PUMP" DER KESSELPUMPE FÜR DIE ELEKTRONISCHE REGELUNG
 PŘIPOJOVACÍ SVORKA "L-PUMP" KOTLOVÉHO ČERPADLA DO ELEKTRONICKÉ REGULACE
- (D) WHEN ELECTRONIC REGULATION CONTROL BOILER FAN - CONNECTORS "PT-C" A "PT-1" MUST BE UNCONNECT
 DEN AUSWECHSELN KONNEKT. "PT-C" UND "PT-1" ABKLEMMEN BEI DER KESSELGÄBLASEBEDIENUNG DER ELEKTRONISCHE REGELUNG
 PŘIPOJOVACÍ KONKOTORY "PT-C" A "PT-1" ODPJOJIT PŘI OVLÁDÁNÍ KOTLOVÉHO VENTILÁTORU ELEKTRONICKOU REGULACI
- (E) WHEN ELECTRONIC REGULATION CONTROL BOILER FAN - CHANGE CONNECTOR "BT-C" FOR CONNECTOR "BT-C REG"
 DEN AUSWECHSELN KONNEKT. "BT-C" FÜR KONNEKT."BT-C REG" BEI DER KESSELGÄBLASE BEDIENUNG DER ELEKTRON. REG.
 PŘEHODIT SVORKY "BT-C" ZA "BT-C REG" PŘI OVLÁDÁNÍ KOTLOVÉHO VENTILÁTORU ELEKTRONICKOU REGULACI
- (F) WHEN ELECTRONIC REGULATION CONTROL BOILER FAN/PUMP/ - CHANGE CONNECTOR "ST-2" TO CONNECTOR "ST-2 REG"
 DEN AUSWECHSELN KONNEKTOR "ST-2" FÜR KONNEKT."ST-2 REG" BEI DER GÄBLASE/PUMPE BEDIENUNG DER ELEKTRON. REGELUNG
 PŘEHODIT SVORKY "ST-2" ZA "ST-2 REG" PŘI OVLÁDÁNÍ KOTLOVÉHO VENTILÁTORU/ČERPADLA ELEKTRONICKOU REGULACI
- (G) WHEN ELECTRONIC REGULATION CONTROL BOILERPUMP - CONNECTORS "TČ95" MUST BE UNCONNECT
 DEN KONNEKTÖREN "TČ95" ABKLEMMEN BEI DER KESSELPUMPE BEDIENUNG DER ELEKTRONISCHE REGELUNG
 KONKOTORY "TČ95" ODPJOJIT PŘI OVLÁDÁNÍ KOTLOVÉHO ČERPADLA ELEKTRONICKOU REGULACI

DCxxs_11-05-01

14. Wiring diagram for DC75SE - electromechanical regulation with an UCJ 4C52 type extraction ventilator, valid from 12/2007

EN

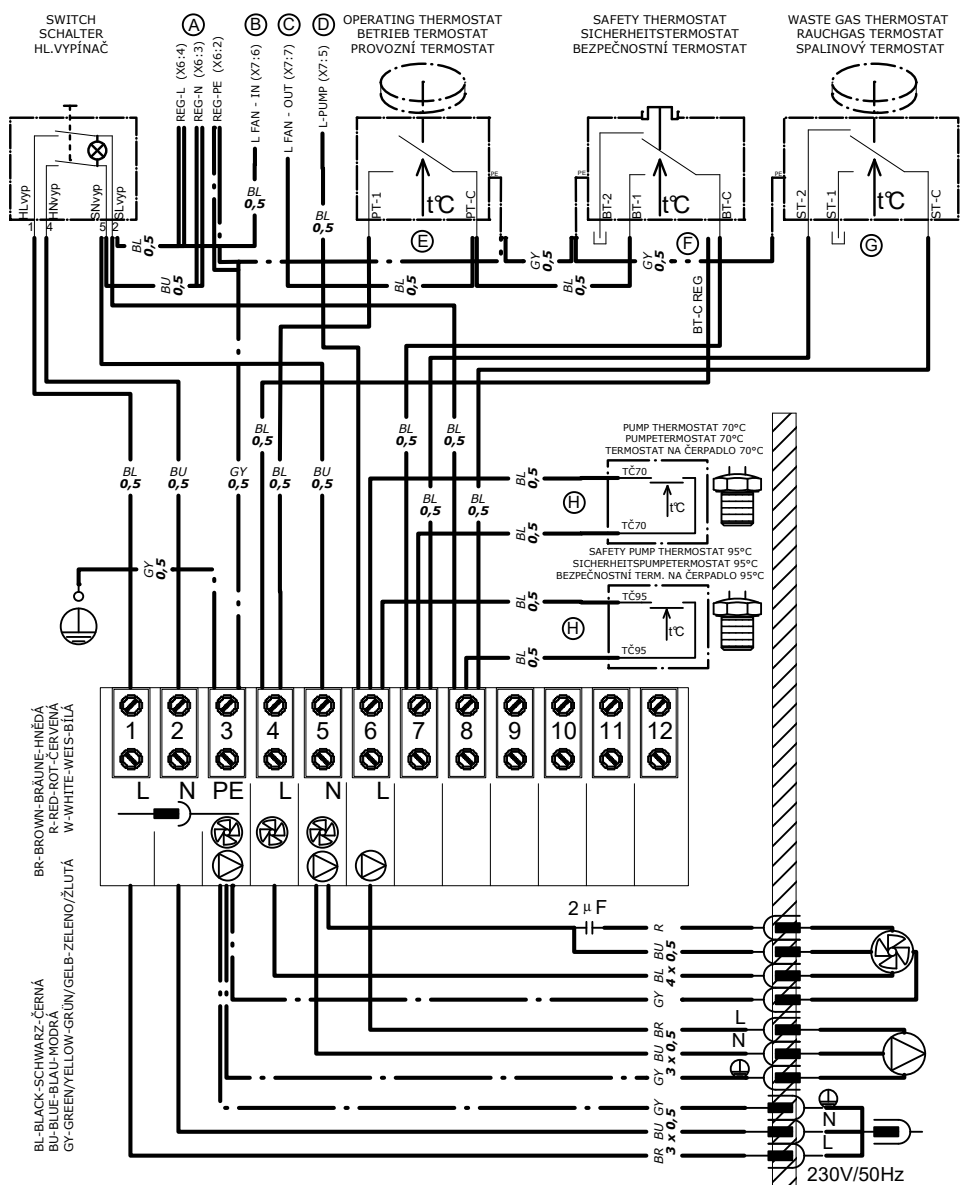

**WHEN USE ELECTRONIC REGULATION ACD01 MUST BE THESE CHANGES OF WIRING:
 BEI DER STEUERUNG DES KESSELBETRIEBES DER ELEKTRONISCHE REGELUNG ACD01 MÜSSEN DIESE ÄNDERUNGEN MACHEN SEIN:
 PŘI ZAPOJENÍ ELEKTRONICKÉ REGULACE ACD01 PŘEVEDTE TYTO ZMĚNY:**

- (A) VARIANTS OF RESERVOIR POINTS "REG L,N,PE" (FERRULE/FASTON 6,3) FOR ELECTRONIC REGULATION
 SPEISEKLEMMENVARIANTEN "REG L,N,PE" (ADERENDHÜLSE/FASTON 6,3) FÜR ELEKTRONISCHE REGELUNG
 VARIANTY NAPÁJECÍCH SVOREK "REG L,N,PE" (DUTINKA/FASTON 6,3) PRO ELEKTRONICKOU REGULACI
- (B) RESERVOIR POINT "L FAN - IN" OF BOILER FAN TO THE ELECTRONIC REGULATION
 SPEISEKLEMME "L FAN - IN" DER KESSELGEBLÄSE FÜR DIE ELEKTRONISCHE REGELUNG
 PŘIPOJOVACÍ SVORKA "L FAN - IN" KOTLOVÉHO VENTILÁTORU DO ELEKTRONICKÉ REGULACE
- (C) RESERVOIR POINT "L FAN - OUT" OF BOILER FAN TO THE ELECTRONIC REGULATION
 SPEISEKLEMME "L FAN - OUT" DER KESSELGEBLÄSE FÜR DIE ELEKTRONISCHE REGELUNG
 PŘIPOJOVACÍ SVORKA "L FAN - OUT" KOTLOVÉHO VENTILÁTORU DO ELEKTRONICKÉ REGULACE
- (D) RESERVOIR POINT "L PUMP" OF BOILERPUMP TO THE ELECTRONIC REGULATION
 SPEISEKLEMME "L PUMP" DER KESSELPUMPE FÜR DIE ELEKTRONISCHE REGELUNG
 PŘIPOJOVACÍ SVORKA "L PUMP" KOTLOVÉHO ČERPADLA DO ELEKTRONICKÉ REGULACE
- (E) WHEN ELECTRONIC REGULATION CONTROL BOILER FAN - CONNECTORS "PT-C" AND "PT-1" MUST BE UNCONNECT
 DEN KONNEKTOREN "PT-C" UND "PT-1" ABKLEMMEN BEI DER KESSELGÄLASEBEDIENUNG DER ELECTRONIC REGELUNG
 KONEKTORY "PT-C" A "PT-1" ODPOJIT PŘI OVLÁDÁNÍ KOTLOVÉHO VENTILÁTORU ELEKTRONICKOU REGULACÍ
- (F) WHEN ELECTRONIC REGULATION CONTROL BOILER FAN - CHANGE CONNECTOR "BT-C" FOR CONNECTOR "BT-C REG"
 DEN AUSWECHSELN KONNEKTOR "BT-C" FÜR KONNEKTOR "BT-C REG" BEI DER KESSELGÄLASEBEDIENUNG DER ELEKTRONISCHE REGELUNG
 PŘEHODIT SVORKU "BT-C" ZA "BT-C REG" PŘI OVLÁDÁNÍ KOTLOVÉHO VENTILÁTORU ELEKTRONICKOU REGULACÍ
- (G) WHEN ELECTRONIC REGULATION CONTROL BOILER PUMP AND FAN - CONNECTORS "ST-C" AND "ST-2" MUST BE UNCONNECT
 DEN KONNEKTOREN "ST-C" UND "ST-2" ABKLEMMEN BEI DER KESSELPUMPEBEDIENUNG UND KESSELGÄLASEBEDIENUNG DER ELEKTRONISCHE REGELUNG
 KONEKTORY "ST-C" A "ST-2" ODPOJIT PŘI OVLÁDÁNÍ KOTLOVÉHO ČERPADLA A VENTILÁTORU ELEKTRONICKOU REGULACÍ
- (H) WHEN ELECTRONIC REGULATION CONTROL BOILER PUMP - CONNECTORS "TČ70" AND "TČ95" MUST BE UNCONNECT
 DEN KONNEKTOREN "TČ70" UND "TČ95" ABKLEMMEN BEI DER KESSELPUMPEBEDIENUNG DER ELEKTRONISCHE REGELUNG
 KONEKTORY "TČ70" A "TČ95" ODPOJIT PŘI OVLÁDÁNÍ KOTLOVÉHO ČERPADLA ELEKTRONICKOU REGULACÍ

DC75SE_11-05-01

15. Wiring diagram of electromechanical regulation of the DC15E type boiler, valid from 12/2007

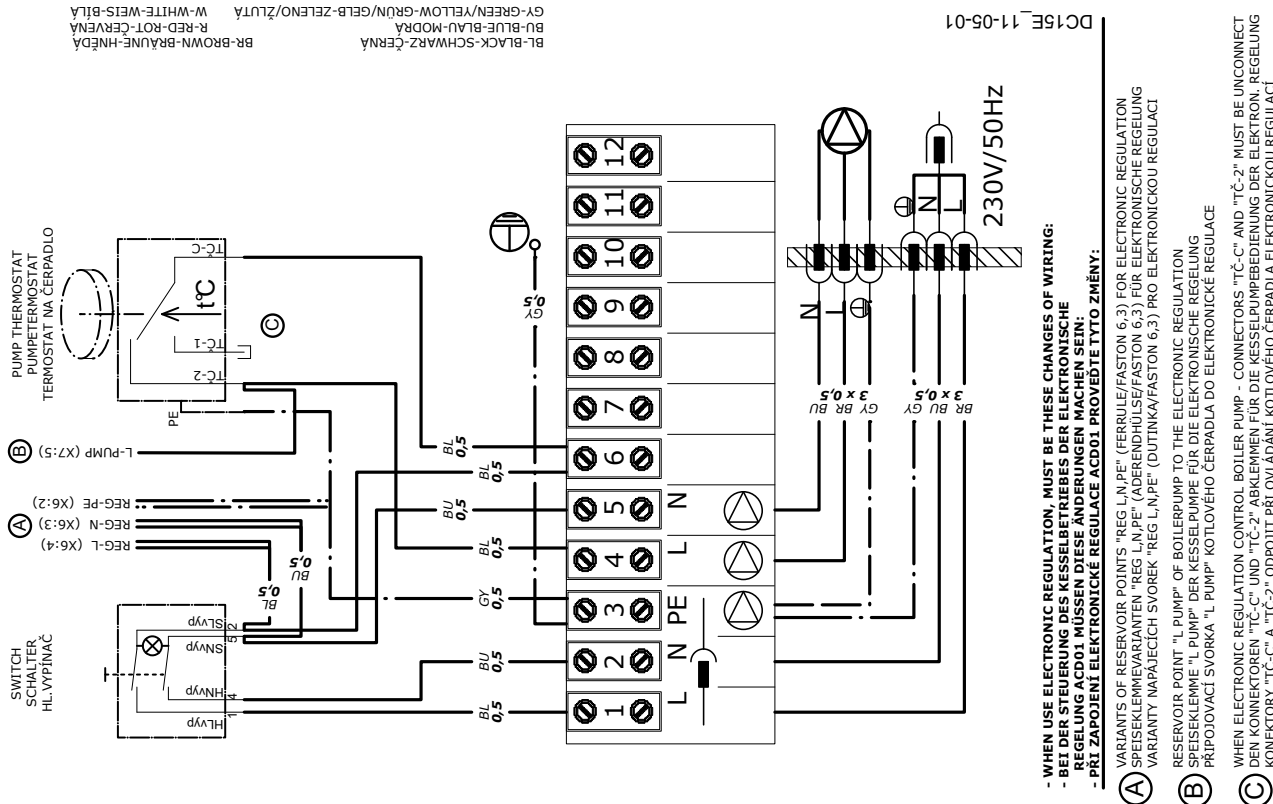

16. Obligatory ČSN EN standards dealing with boiler designing and boiler assembly

- | | |
|----------------|---|
| ČSN EN 303-5 | - Solid fuel boilers for central heating |
| ČSN 06 0310 | - Central heating, designing and assembly |
| ČSN 06 0830 | - Safety devices for central heating and hot potable water heating |
| ČSN EN 73 4201 | - Designing chimneys and flue-gas ducting |
| ČSN EN 1443 | - Chimney structures – general requirements |
| ČSN 06 1008 | - Fire safety of local appliances and heat sources |
| ČSN EN 13501-1 | - Fire classification of construction products and construction of buildings - Part 1 |
| ČSN EN 1264-1 | - Floor heating – Systems and components – Definitions and symbols |
| ČSN EN 1264-2 | - Floor heating – Systems and components – Heat output calculation |
| ČSN EN 1264-3 | - Floor heating – Systems and components – Designing |
| ČSN EN 442-2 | - Heaters – Testing and test analysis |

Standards for evaluation of conformity and other technical standards:

ČSN EN ISO 12100:2012, ČSN EN 953+A1:2009, ČSN EN ISO 11202:2011, ČSN EN ISO 3746:2011, ČSN ISO 1819:1993, ČSN EN 60335-1ed.2:2003



CAUTION – the boiler must be installed in compliance with a design prepared in advance. Installation may only be carried out by persons trained by the manufacturer.

17. Choice and connection method of control and heating elements

EN

Boilers are provided to the user with the basic boiler performance control elements compliant with requirements for convenient heating and its safety. The regulation ensures that the required temperature of the water exiting the boiler (80 - 90 °C) is adhered to. The control of mixing valves and pumps is not solved. With the exception of DC75SE, which is equipped with two thermostats 70 °C (pump connection temperature during normal operation), 95 °C (pump connection temperature during emergency state) for switching the pump in the boiler circle and with the exception of DC15E, which is equipped with thermostat place in the panel and an outlet for the pump in the boiler circle. Connection of these elements is illustrated in the wiring diagram. Each pump in the system must always be controlled by an individual thermostat to avoid a temperature drop of water returning to the boiler under 65 °C. When connecting the boiler without an accumulation tank or equalizing tank, the pump placed in the heated building circuit must be switched on and off by an individual thermostat or electronic regulation so that it only operates when the pump in boiler circuit operates. If two thermostats are used – each for switching one pump – set the thermostat that switches the heated building circuit pump, to 80 °C, and the thermostat that switches the boiler circuit pump, to 75 °C. Both pumps may only be switched by one thermostat. We recommend to switch the pump in the boiler circle by the means of waste gas thermostat built in the boiler (during fire-up), if the boiler is connected with the accumulation tanks and the if the gravity water circulation which prolongs the required temperature build up functions well in the boiler circle. When switching the pump in the boiler circle by using the waste gas thermostat built in the boiler panel, we recommend to install safety thermostat on the 95 °C pump (see electric wiring diagrams). Thermostat in the boiler can be alternatively replaced with an attaching thermostat on the boiler outlet which connects the pump in the boiler circle when the temperature rises to 95 °C (parallel connection with the waste gas thermostat).

Setting the required water temperature for the building is always achieved by means of a three-way mixing valve. The mixing valve can be regulated manually or by electronic regulation, which contributes to a more convenient and economical operation of the heating system. The connection of all the elements is designed to suit specific conditions of the heating system. Electric installations related to the additional equipping the boilers with the above mentioned elements must be carried out by an expert in compliance with valid ČSN EN standards.



When installing the boiler, can be use a open expansion vessel. However a close expansion vessel may also be used if permitted in the standards of the specific country. The boiler must always be installed in a way which prevents overheating (and subsequent damage) even during a power cut. It is because the boiler has certain momentum.



There are several ways of protecting the boiler from overheating. Connecting an overheat prevention cooling loop with a TS 131 3/4 ZA (95 °C) or WATTS STS 20 (97 °C) valve to the public water system. In cases of personal wells, the boiler can be additionally protected by using a back-up power supply (battery with an exchanger) for operation back up of at least one pump. Another option is connecting the boiler to an after-cooling tank and reversal zone valve.



When installing the boiler, position the rear section 10 mm higher in order to facilitate circulating and air-bleeding.

For the heating system regulation we recommend regulation elements provided by the following companies:

- a) ATMOS ACD 03 / 04 - Eqvithermal controller for solid fuel boilers
- b) ATMOS ACD 01 - Eqvithermal controller set for solid fuel boilers
- c) KOMEX THERM, Praha tel.: +420 235 313 284
- d) KTR, Uherský Brod tel.: +420 572 633 985

18. Boiler corrosion protection

The specified solution is connecting the boiler with Laddomat 22 or thermoregulatory valve, which can separate the boiler circuit from the heating circuit (primary and secondary circuits), and provide **minimum of 65 °C for water returning to boiler**. As other recommended connection it is also possible to keep the minimum temperature of the returning water (65 - 75 °C) by utilising a three-way mixing valve with an actuator and electronic controller ACD 01, ACD 03, ACD 04.

The higher the temperature of water returning to the boiler, the fewer tars and acids condensing; which damage the boiler. **Temperature of the outgoing water must permanently range between 80 - 90 °C**. The combustion products (waste gas) temperature must not drop **below 110 °C** during normal operation. Low waste gas temperature causes condensation of tars and acids even when the specified outgoing water temperature of (80 - 90 °C) and returning water temperature of (65 °C) are adhered to. These conditions may occur when using the boiler to heat domestic hot water (DHW) in summer, or when heating only a section of the building. In this case we recommend connecting the boiler with accumulation tanks, or daily firing-up.

19. Specified basic boiler connection with Laddomat 22

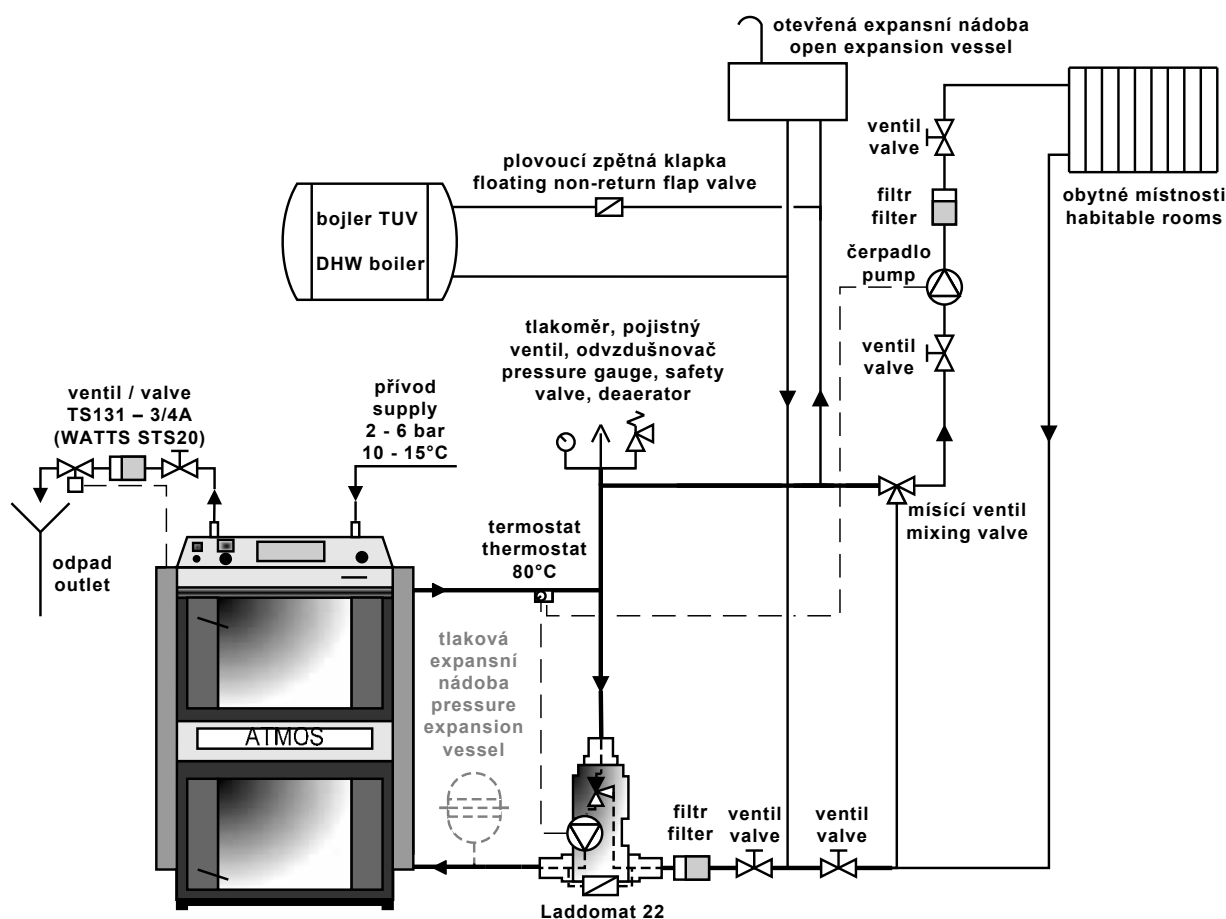

20. Specified basic boiler connection with thermoregulation valve

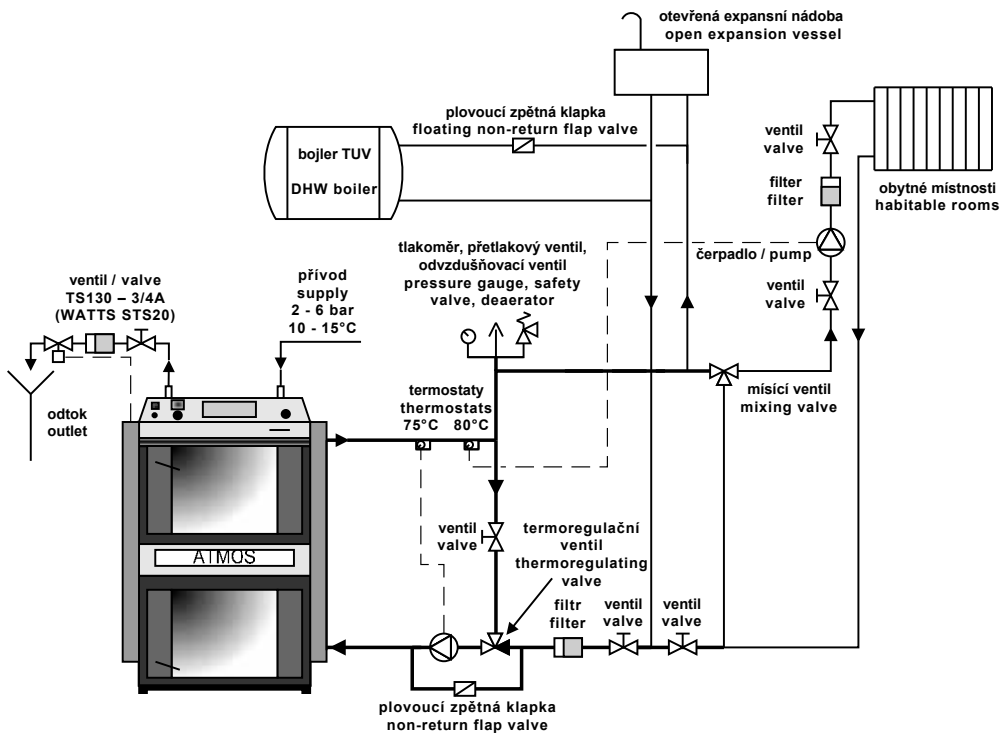

ATTENTION – when connecting the cooling loop to prevent overheating, it is possible to omit the return valve on the thermo-valve and pump by pass.

21. Boiler connection with buffer tank and controlled three-way mixing valve with actuator

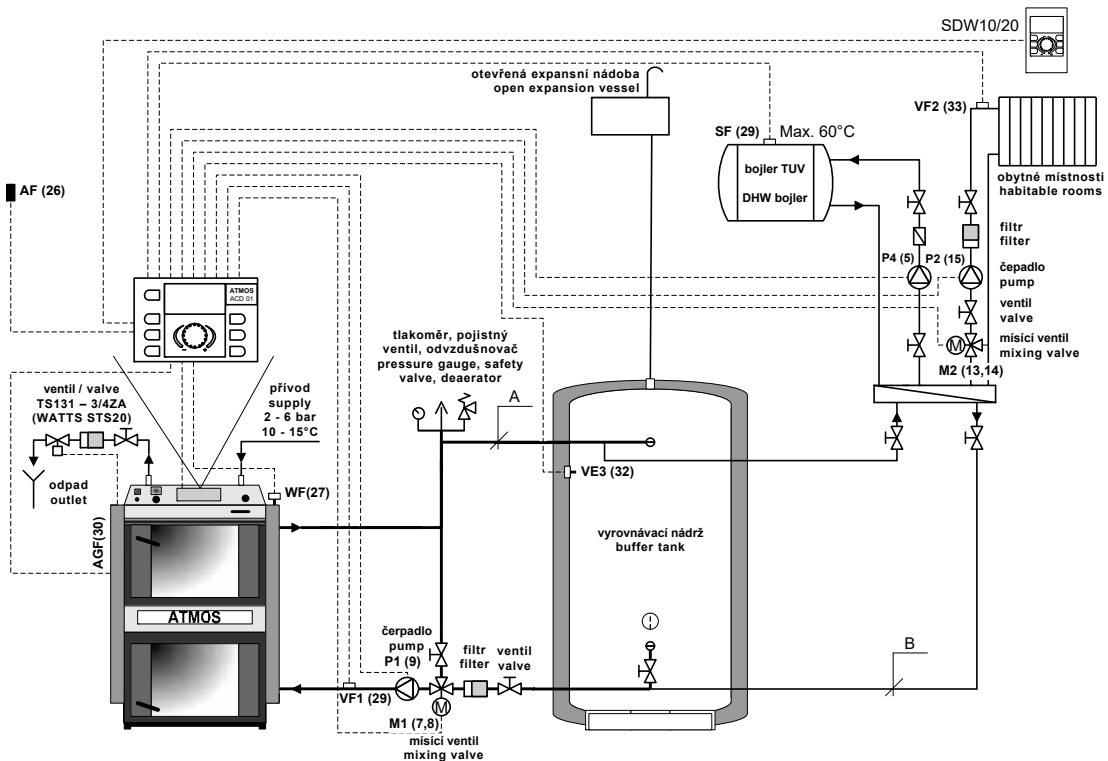

22. Recommended wiring diagram with Laddomat 22 and accumulation tanks

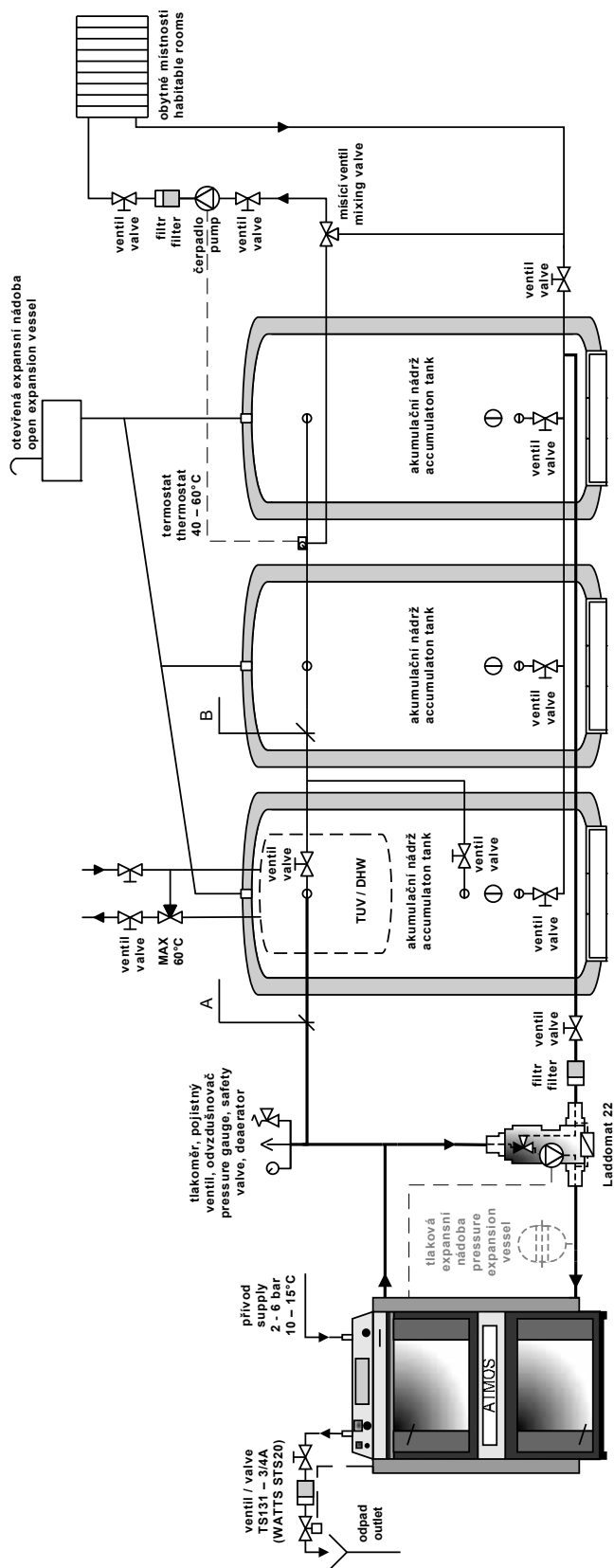

When connecting the boiler with accumulation tanks, we recommend to switch the pump in boiler circuit with an waste-gas thermostat build in the boiler, see section 17, page 22.

Pipeline diameters if connected with accumulation tanks

Boiler type and output	section A		section B	
	in copper	in steel	in copper	in steel
DC15E, DC18S, DC15GS, DC20GS	28x1	25 (1")	28x1	25 (1")
DC22S, DC25S, DC25GS, DC22SX, DC30SX	28x1	25 (1")	28x1	25 (1")
DC32S, DC32GS, DC30SE	35x1,5	32 (5/4")	28x1	25 (1")
DC40GS, DC40SE, DC40SX	35x1,5	32 (5/4")	28x1	25 (1")
DC50S, DC50SE	42x1,5	40 (6/4")	35x1,5	32 (5/4")
DC70S, DC75SE	54x2	50 (2")	42x1,5	40 (6/4")

23. Laddomat 22

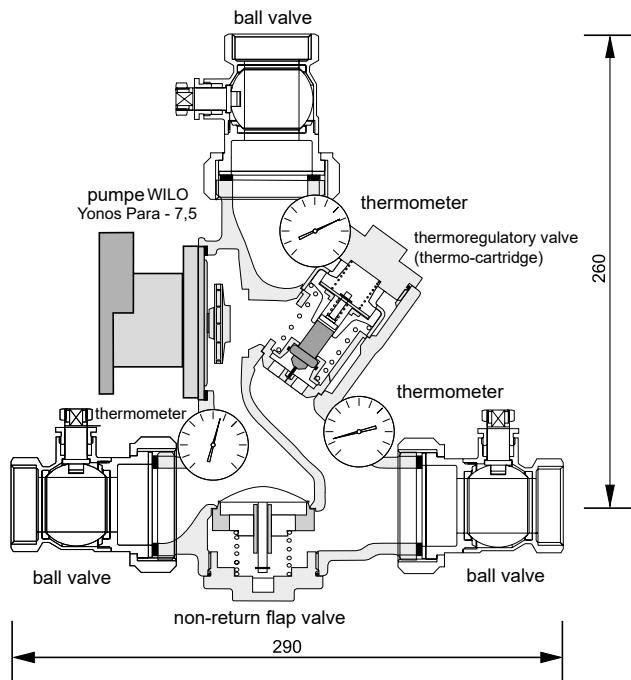

With its construction, Laddomat 22 replaces the traditional connection composed of individual parts. It is composed of a cast-iron body, thermoregulatory valve, pump, non-return flap valve, ball valves and thermometers. When the water temperature reaches 78 °C, the thermoregulatory valve opens the water supply from the storage tank. The connection with Laddomat 22 is considerably easier and therefore, we recommend it. A spare thermo-cartridge of 72 °C is supplied with the Laddomat 22 device. It is used for boilers over 32 kW.

OPERATION DATA	
Max. operating pressure	0,25 MPa
Design pressure	0,25 MPa
Test over pressure	0,33 MPa
Highest operating temperature	100 °C



WARNING - For boilers with an output from 15 up to 100 kW we recommend using Laddomat 22, which is factory fitted with thermo-cartridge of 78 °C.

24. Thermoregulatory valve

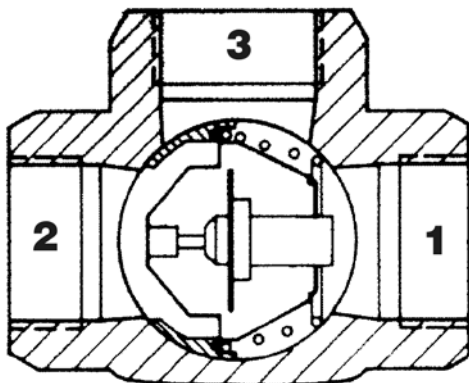

Thermoregulatory valve type, TV 60 °C (65/70/72/77 °C) is used with solid fuel boilers. When the boiler water temperature reaches + 60 °C (65 °C) , the thermoregulatory valve opens and fluid from the building heating circuit (2) enters the boiler circuit (3 →1). Inlets 1 and 3 always remain open. This ensures that the minimum temperature of the water returning to the boiler is maintained. If need be, a thermoregulatory valve set to a higher temperature (E.g. 72 °C) may be used.

Recommended sizes of the thermoregulatory valve TV 60 °C (65/70/72/77 °C).

For boilers:

D15E, DC18S, DC15GS, DC20GS, DC22S, DC22SX DC25S, DC25GS, DC30SX DN 25
 DC32S, DC32GS, DC40GS, DC40SE, DC40SX DN 32
 DC50S, DC50SE, DC70S, DC75SE DN 40, DN 50

25. Operating a system with accumulation tanks

Ignite the boiler and allow the accumulation tanks to “charge” to the required water temperature of 90 - 100 °C by the boiler’s maximum output operation (2 to 4 loads). Then leave the boiler to stop burning. Then keep withdrawing heat from the storage utilising three-way valve for a period of time corresponding to the size of accumulation tanks and the external temperature. In the heating season (and if adhering to specified min. accumulation tanks volumes – see chart) this could take 1 - 3 days. If the accumulation method cannot be used, then we recommend using at least one tank of 500 - 1000 l volume for equalising the boiler start-ups and run-outs.

RECOMMENDED MINIMUM ACCUMULATION TANK VOLUMES									
Type	DC15E DC15GS	DC18S DC20GS	DC22S DC22SX	DC25S DC25GS DC30SX	DC32S DC32GS	DC40GS DC40SE DC40SX	DC50S DC50SE	DC70S DC75SE	DC100
Output	15	20	22	25	32	40	49	70	99
Volume	1000 - 1500	1000 - 1500	1500 - 2000	1500 - 2000	2000 - 2500	2500 - 3000	3000 - 4000	4000 - 5000	5000 - 6000

The standard ATMOS accumulation tanks provided

TANK TYPE	VOLUME (l)	DIAMETER (mm)	HEIGHT (mm)
AN 500	500	600	1970
AN 600	600	750	1611
AN 750	750	750/790*	2010/1750*
AN 800	800	790*	1910*
AN 1000	1000	850/790*	2065/2210*

* type DH

Tank insulation

A suitable solution is joint mineral wool insulation of the particular number of tanks (of required volume) placed together into a plasterboard structure, or additional filling with granular insulation. When using the mineral wool, the specified minimum insulation thickness is 120 mm. Another option is purchasing tanks in a leather-cloth housing insulated by mineral wool (see the price list).

Advantages

The installation with accumulation tanks provides several advantages:

- lower fuel consumption (by 20 – 30 %), the boiler operates in full output and at an optimal effectiveness of 81 - 89 % until the complete combustion of the fuel
- prolonged boiler and chimney service life – minimum formation of wood-tars and acids
- possibility to combine it with other heating methods – accumulated electric power, solar collectors
- combination of wall radiators and floor heating
- convenient heating and ideal fuel combustion
- environmentally friendlier heating

26. Connection of overheat protecting cooling loop with a safety valve Honeywell TS 131 - 3/4 ZA or WATTS STS20 (valve opening temperature 95 - 97 °C)

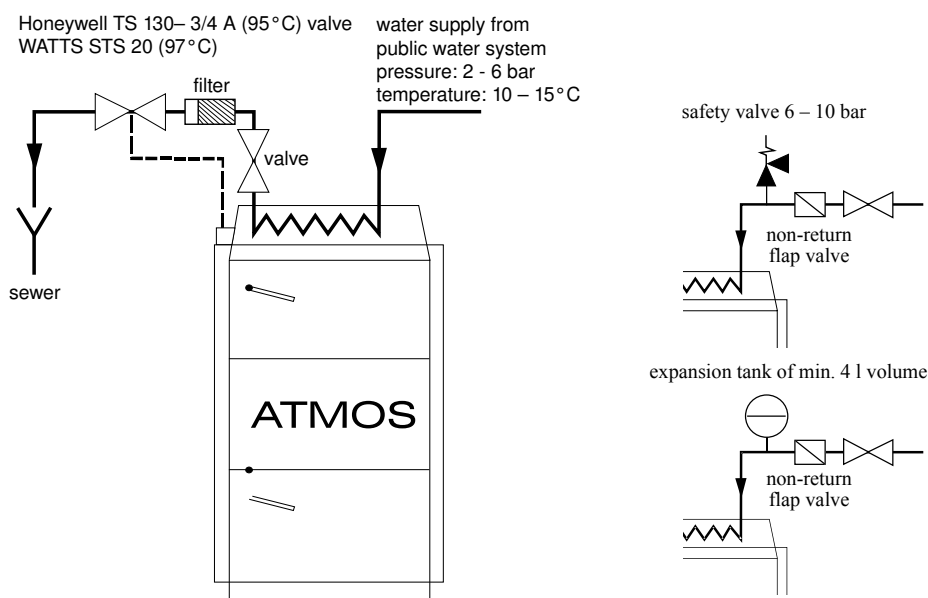

ATTENTION – cooling loop to prevent overheating must be used in compliance with EN ČSN 303-5 only for overheating prevention (never for heating up warm service water).

The TS 131 - 3/4 ZA or WATTS STS 20 valves, the sensor of which is placed in the rear of the boiler, prevent overheating in the following way: if the boiler water temperature rises above 95 °C, the valve opens and allows water from public water supply system to enter the cooling loop. This water then absorbs the excessive energy and exits to the sewer. In case that a non-return flap valve has been installed to the cooling loop water inlet for the purpose of preventing reversed water flow (which might be caused by pressure drop in the public water supply system), the cooling loop must be fitted with a 6 – 10 bar safety valve or with an expansion vessel of minimum 4 l volume. The boiler must be protected against overheating at all times. If not, its damage or burst may occur.

27. Operating instructions

Preparing boilers for operation

Before putting boilers into operation, it is necessary to ensure that the system has been filled with water, and air-bled. Wood boilers must be operated in compliance with the instructions stipulated in this manual so that satisfactory and safe functioning is achieved. They can only be operated by adults.

Ignition and operation

Before fuel ignition, open the ignition valve /13/ by pulling the ignition valve pulling rod /17/ and reduce the waste gas thermostat (except DC15E, DC70S) for the ignition (to minimum - 0 °C) which will start the exhaust fan of the boiler. Through the top door /2/ insert dry wood kindling on the heatproof shaped piece /5/. Place the kindling perpendicularly to the channel recess in the shaped piece so that a 2 – 4 cm gap between the recess and fuel is created; which allows the waste gas

passage. Place paper or wood wool on top of the kindling, then another layer of kindling and larger amount of dry wood. After ignition close the top door and open the lower door. When the fuel has caught sufficient fire, close the lower door, fill the storage tank completely with fuel and close the ignition valve with its pulling rod /17/. Set the waste gas thermostat into the operating position which it is necessary to determine for ideal operation. On the FR 124 draught (output) regulator /22/ set the required outgoing water temperature 80 - 90 °C (note – DC50SE is not equipped with draught regulator FR 124). If the boiler should work as a gasification appliance, then a layer of glowing charcoal must be kept (known as reduction zone) above the gasifying nozzle. This can be achieved by burning dry firewood of suitable size. When burning moist wood, the burner does not operate as a gasification appliance, the fuel consumption increases dramatically, the boiler does not reach the required output and the service life of both - the boiler and the chimney - decreases. If the specified chimney draught is adhered to, the boiler operates up to 70% output without the ventilator.

Waste gas thermostat setting

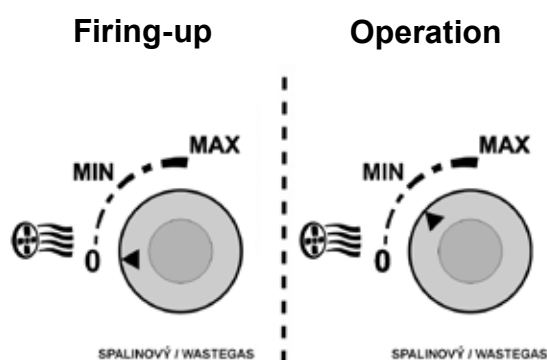

Ignition valve operating

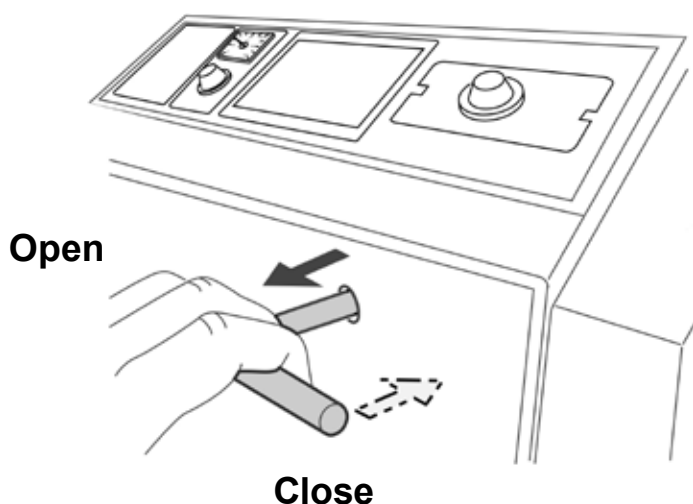

NOTE – when burning wood for the first time, condensation occurs and condensed fluid leakage occurs – this is not a defect. Condensation will disappear later. When burning small wood waste particles, it is necessary to monitor the waste gas temperature which must not exceed 320 °C. Otherwise, the ventilator (S) may sustain damage. **Wood-tar and condensate formation in the hopper is a side effect of wood gasification.**



ATTENTION – during operation, all doors must be shut and the ignition valve pulling rod must be inserted, otherwise the ventilator (S) may sustain damage.

Output regulation - electromechanical

Output regulation is achieved by means of a control flap valve /8/ operated by the FR 124 draught regulator /22/ which automatically opens up or shuts down the valve /8/; depending on the pre-set outgoing water temperature (80 - 90 °C) (DC50SE excluded). The output (draught) regulator adjustment should be done carefully because it not only regulates the output; but also protects the boiler against overheating. The setting should be in compliance with the enclosed ‚Assembly and Setting Instructions‘

for the HONEYWELL Braukmann FR 124 type regulator. The overheat protection function can be monitored by checking the regulator's functionality at temperature of 90 °C. At this temperature, the control valve /8/ must be almost closed. It is necessary to seek and discover the best setting. You can visually inspect the control valve's /8/ position by looking from the rear side of the ventilator. The ventilator is controlled by a control thermostat situated on the boiler's panel. The regulation is based on the pre-set outgoing temperature value. The temperature set on the thermostat should be 5 °C lower than the temperature set on the FR 124 draught regulator. (Indicated by dots on the thermostat scale). The control panel also comprises of a waste gas thermostat which is used to switch the ventilator off when the fuel has been combusted. When igniting, position to the "firing-up" position (minimum value). When the fuel has sufficiently flared up, set it to the operating position in which the ventilator runs until the fuel has completely burnt out. It is necessary to seek and discover an optimal position of the thermostat; which depends on type of fuel, chimney draught and other conditions. The outgoing water temperature should be monitored on the thermometer /18/ situated on the control panel. There is also an irreversible safety thermostat on the panel. Wood supply gasification boiler DC50SE is not equipped with Honeywell draught regulator FR 124 and typical regulation valve (aperture for FR 124 on the water outlet from the boiler must be blinded). It is equipped with regulation valve with a servo-drive and spring placed in the combustion air inlet. This valve is controlled with regulation and waste gas thermostat in accordance with outlet water temperature; like the draught ventilator. When the thermostat is switched off, it switches off automatically. Regulation valve is set by the manufacturer to a maximum opening of 30 mm. Maximum valve opening can be altered as necessary. This can change the boiler output and its combustion. Boiler DC15E is not equipped with a ventilator, regulation, waste gas and safety thermostat. Output regulation is carried out only with Honeywell FR 124 draught regulator, which controls the regulation air valve. Panel on DC15E type is equipped with a switch and thermostat for a pump.

Draught regulator - HONEYWELL Braukmann FR 124 – Assembly instructions



Disassemble the lever /1/ and coupler /2/ and screw the regulator into the boiler.

Setting

Heat the boiler to approx. 80 °C. Set the setting handle to the temperature read on the boiler thermometer. Tension the air flap valve chain in a way that provides the required boiler output; the gap at the air (control) flap valve may range between 3 - 50 mm. The valve minimum gap is set by a setscrew to 3 - 8 mm; boiler service-life prolonging feature, do not decrease. Otherwise, the boiler and ventilator may get covered in tar and their service life would be reduced. In cases where there are insufficient general draught conditions, slightly increase the permissible minimum gap.

Draught regulator functional check

Set the setting handle to the required temperature of water exiting the boiler (80 - 90 °C). When the water temperature reaches its maximum of 95 °C, the control flap valve must be fully closed (only providing the setscrew gap). It is always necessary to fine-tune the specified operating temperature (80 - 90 °C) utilising the mixing valves behind the boiler either manually or by electronic regulation with electric actuator.

28. Boiler output and combustion setting

For boilers DCxxS(X), DCxxGS with exhaust fan - version A

Setting of primary - air ratio

Optimum setting:

Fully closed (5 mm) + 8÷10 mm

Maximum setting:

Fully closed (5 mm) + 10÷20 mm

Setting of secondary - air ratio

Optimum setting:

Fully closed (5 mm) + maximum (completely pulled out)

Minimum setting:

Fully closed (5 mm) + 5 mm

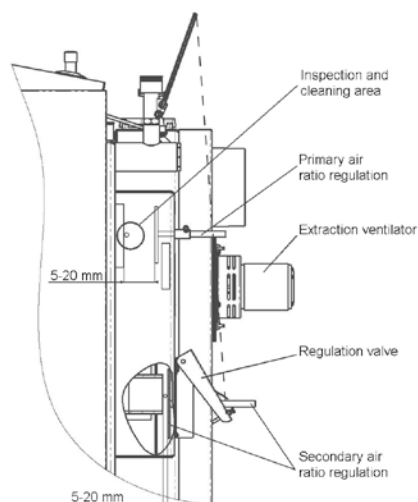

The regulation is carried out by either pulling out (+) or retracting (-) the regulating pulling rod.

For boilers DCxxS/SX/SE, DCxxGS with exhaust fan - version B

Setting of primary-secondary air ratio

Optimum setting:

fully closed (5 mm) + 5÷10 mm

Maximum setting:

fully closed (5 mm) + 10÷20 mm

Basic setting of primary-secondary air ratio for DC75SE boiler

Optimum setting:

fully closed (20 mm) + 5÷10 mm

Maximum setting:

fully closed (20 mm) + 10÷20 mm

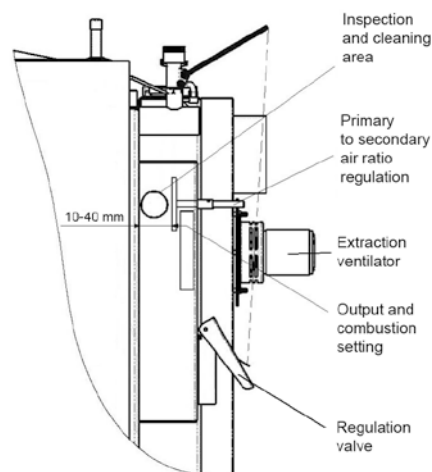

The regulation is carried out by either pulling out (+) or retracting (-) the regulating pulling rod.

Basic setting of the added secondary air for boiler DC50S (front air)

We regulate by turning the adjusting screw. By turning the screw by 1 revolution anticlockwise we open the secondary air by 1,75 mm (1 revolution = 1,75 mm). **The manufacturer set the regulation to approx. 2 mm opening (up to the stop + 1 turn anticlockwise).**

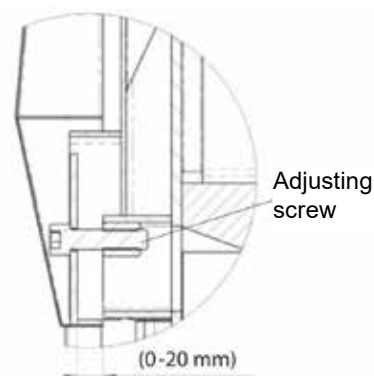

For boiler DC70S with blower fan

Basic setting of primary air ratio:

Optimum setting:

fully closed (5 mm) + 8÷10 mm

Maximum setting:

fully closed (5 mm) + 10÷20 mm

Basic setting of secondary air ratio:

Optimum setting:

fully closed (8 mm) + 0 mm

Maximum setting:

fully closed (8 mm) + 5÷20 mm

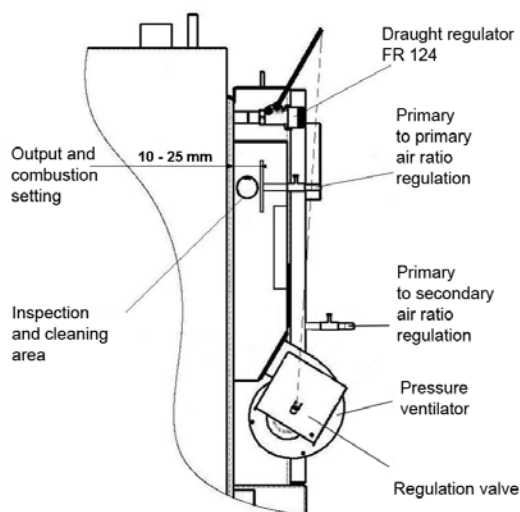

The regulation is carried out by either pulling out (+) or retracting (-) the regulating pulling rod.



INFO - Adjustments to settings should be done on the basis of the waste gas analyzer and maximum temperature; which must not exceed 320 °C at the outlet to chimney, at stabilised nominal output /with closed ignition valve/. The boiler is set to optimal operating parameters by the manufacturer. Therefore, make adjustments to settings only in cases where the operation conditions are non-standard (for example - if insufficient chimney draught, pull the regulator pulling rod to its maximum).

29. Fuel refill

Before fuelling, open the ignition valve /13/ with the pulling rod /17/. Do not switch the extraction ventilator off. Wait for approximately 10 seconds and slowly open the loading door /2/ so that any accumulated gases are first vented off into the flue-gas duct and not in the boiler room. Before opening the DC70 door, switch the pressure ventilator /4/ off using switch /20/. Cover the glowing charcoals with a wide log. Do not press the fuel on the gasifying nozzle, it can put the flame out. Always fill the hopper completely. In order to prevent excessive smoke formation, load new batch of fuel only after the previous fuel has combusted to at least one third of the loading volume.



CAUTION – during operation, the ignition valve pulling rod must be retracted, otherwise damage to the ventilator (S) will occur. Otherwise, the ventilator (S) will sustain damage.

30. Steady heat operation

It is possible to use boilers for slow-burning operation, i.e. keeping the fire up overnight without the necessity to heat-up during the day. This is **only permitted during wintertime**. This operating method however decreases the boiler service life. Prepare the boiler for slow-burning operation in the following way:

- place several (4 – 6) larger logs on a glowing layer of partially combusted fuel
- turn the mixing valve down
After the valve has been turned down, the boiler water temperature increases to 80 - 90 °C.
- the control flap valve /8/ operated by the FR 124 Honeywell draught regulator automatically shuts down and the ventilator switches off (DC15E excluded) – the boiler operates in maximum output mode

In boilers prepared as previous, the fuel burns for 8 – 12 hours. The actual slow-burn combustion time depends on the amount of fuel placed in the boiler and on the actual quantity of consumed heat. **Even if the boiler operates in the slow-burn mode, it has to keep the output water temperature ranging between 80 - 90 °C and returning water minimum temperature 65 °C.**

31. Boiler cleaning

It is necessary to clean the boilers regularly and thoroughly every 3 to 5 days because the flue cinder accumulated in the fuel storage tank together with tars and acids dramatically decreases the boiler's service life and output and insulates the heat transfer surface. If excessive amount of cinder in the lower chamber is left to form, then the burn-off area is insufficient and damage to the ceramic nozzle handle or the boiler may occur. Carry out the cleaning procedure by first switching the extraction ventilator on (except for DC15EP), then open the loading door /2/ and sweep the cinder down through the slot into the lower chamber. Leave long pieces of wood which has not fully combusted (charcoals) in the hopper for the next time the boiler is used. Open the cleaning lid /15/ and clean the rear duct with a brush. If the brake valve is inserted in the duct (corrugated sheet), it must be removed before cleaning. Remove all the soot and cinder after opening the lower lid /15/. Open the lower door /3/ and clean the lower chamber from cinder and soot. Remove the layers of dust on the side walls of the lower combustion chamber with a poker or a brush. If there is a roof in the lower combustion area which contains a breaker (corrugated sheet – DC30SX, DC40SX, DC50S, DC75SE), it is necessary to remove the breaker when cleaning and removing the ash. The cleaning interval depends on the fuel quality (wood moisture content), heating intensity, chimney draught and other factors. We recommend cleaning the boilers once a week. Do not pull out the fireclay shaped piece /10/, /14/, /38/, /39/ when cleaning. At least once a year clean the extraction ventilator rotating wheel and via the cleaning hole, inspect the state of the primary to secondary air ratio regulation. For boilers DC50SE, special sheets are placed on the sides next to the gasification nozzles; the sheets improve the combustion quality. Area underneath these sheets must be cleaned regularly once per 7 to 14 days. Boilers DC70S must be checked at least 2x a year and the compressive ventilator and the air duct may need cleaning. If necessary, clean the area behind the heating area rear screen from tars and ash /41/, /19/.



Open bottom space of the boiler with a roof and example of ash removal with a poker



Open bottom space of the boiler with a spherical chamber and example of ash removing with an ash pan



Sample cleaning of the flue way with a wire brush - upper lid



Sample cleaning of the flue way - bottom lid



Sample cleaning of impeller and checking uprightness of vane on extract ventilator



Checking and cleaning regulation of primary-secondary air ratio via cleaning lid

Ceramic ash areas

For type

- DC18S
- DC15GS
- DC20GS
- DC22SX
- DC25GS
- DC32GS
- DC40GS
- DC30SE

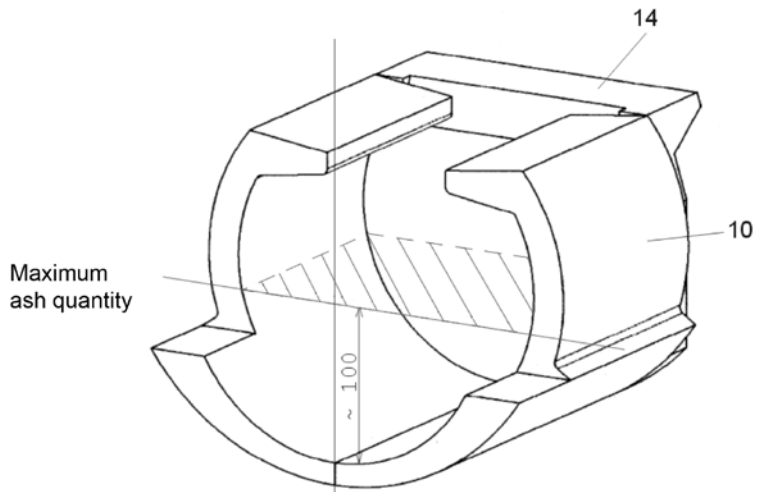

For type

- DC15E
- DC18S
- DC22S
- DC25S
- DC30SX
- DC32S
- DC50S
- DC40SE
- DC40SX
- DC50SE
- DC75SE

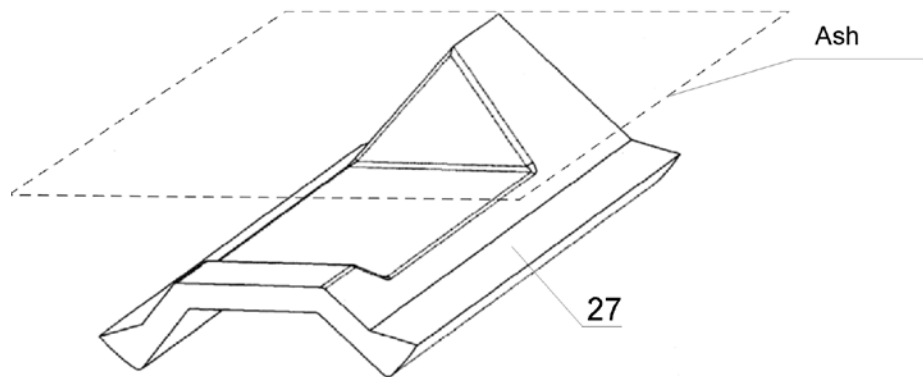

Maximum ash quantity – only up to the upper roof’s edge level!

For type

- DC15E

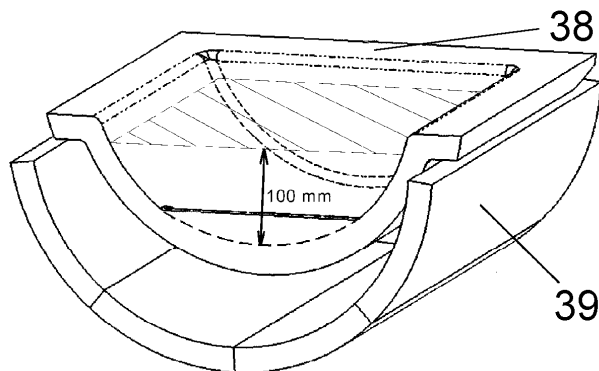

Maximum ash quantity!



NOTE –regular and thorough cleaning is important for permanent stabilised output and a long service life of your boiler. If not cleaned properly, damage to the boiler may occur –the manufacturer’s guarantee is rendered invalid

32. Heating system maintenance - including boilers

EN

Inspect at least once every 2 weeks. If necessary, refill the system with water. If the boilers are out of operation during wintertime, a risk of water freezing in the system arises. Therefore, we recommend letting all the water out from the system or fill it with an anti-freeze. In other situations, only let water out if necessary and keep without water for as little time as possible. After the heating season is over, clean the boiler thoroughly and replace damaged parts. Do not leave parts replacement for the last moment; prepare your boiler for the heating season as early as Spring.

33. Use and inspections

Boiler operators must always follow the operation and maintenance instructions. Interventions into boilers that could endanger the health of the operators or other persons in the vicinity are prohibited. Boilers may only be operated by a person that is more than 18 years old, that has been acquainted with the instructions and operation of the equipment and that complies with the requirements of § 14 of the Directive no. 24/1984 Coll. The boiler operation needed increased attention to safety in terms of potential burns from hot boiler parts and systems. You must never leave unattended children near boiler that is in operation. During the operation of solid fuel boilers it is prohibited to use any flammable liquids for lighting the fire and it is also prohibited to increase the nominal output of the boiler during operation (overheating). **You must not put flammable objects on the boiler and near the fuel feeding and ash pan openings and ash must be stored in non-flammable containers with a lid.** When handling fuel and ash, wear protective equipment (gloves, dust mask). Boilers in operation must be under occasional supervision of the operator. The user may only carry out repair consisting in simple replacement of a spare part (e.g. a sealing cord, etc.). During the operation check the doors and cleaning openings for tightness and always tighten them properly. The user must not alter the structure and electric installation of boilers. The boiler must always be cleaned properly and in time so that free passage of all the ways can be guaranteed. Cleaning doors must always be properly closed.



CAUTION - Follow valid fire regulations and have in reach portable fire extinguisher. If any non-standard behavior of the boiler shut down the boiler from operation and call the service.

34. Possible failures and troubleshooting

Failure	Reason	Solution
The “mains” indicator not lit up	<ul style="list-style-type: none"> - no voltage in network - plug incorrectly inserted to el. socket - defective power supply switch - defective electric cord 	<ul style="list-style-type: none"> - check - check - replace - replace
Boilers do not reach their required outputs and the pre-set water temperatures	<ul style="list-style-type: none"> - not enough water in the system - excessive pump output - the boiler output is not sufficiently rated for the particular heating system - low quality fuel (high moisture content, over sized logs) - ignition valve leaking 	<ul style="list-style-type: none"> - refill - adjust the pump’s switching and flow rate - design issue - use dry firewood and split logs into halves - repair
Boilers do not reach their required outputs and the pre-set water temperatures	<ul style="list-style-type: none"> - insufficient chimney draught - excessive chimney draught - Bent blades of draught ventilator (ignition too long or boiler operated with the ignition flap open) - insufficiently cleaned boiler - combustion-air inlet to loading chamber is clogged 	<ul style="list-style-type: none"> - new chimney; unsuitable connection - place a throttle valve (draught limiter) in the flue-gas duct - pull the draught regulator pulling rod out - straighten blades (to a 90° angle) - replace - clean - clean
doors leaking	<ul style="list-style-type: none"> - defective fibreglass cord - the nozzle becomes clogged - insufficient chimney draught 	<ul style="list-style-type: none"> - replace - adjust the door hinges - do not burn small-particle wood, sawdust, bark - chimney defect
Ventilator does not turn	<ul style="list-style-type: none"> - boiler overheated – safety thermostat fuse out - rotating wheel clogged - defective capacitor - defective motor - bad contact in plug of motor cable lead 	<ul style="list-style-type: none"> - press the thermostat push-button (using a pencil) - clean the ventilator including the ducting from tar and sediments - replace - replace - check - measure

35. Spares

Heatproof shaped piece – nozzle heatproof shaped piece	/5/
Heatproof shaped piece	/9/, /10/, /11/, /12/, /14/, /23/, /27/, /31/, /32/, /38/, /39/
Ventilator (code: S0131), DC75SE (code: S0136)	/4/
Switch with an indicator light (code: S0091)	/20/
Thermometer (code: S0041), DC75SE (code: S0056)	/18/
Control thermostat (code: S0021), DC75SE (code: S0024)	/24/
Safety thermostat (code: S0061)	/36/
Pump thermostat (DC15E) (code: S0023)	/40/
Waste gas thermostat (code: S0031), DC75SE (code: S0019)	/35/
Door sealing cord 18 x 18 (code: S0241)	/26/
Door filling - Sibrál (code: S0261)	/25/
Condenser for draught ventilator UCJ4C52 - 1 μ F (code: S0171)	/29/
Condenser for draught ventilator UCJ4C82 - 2 μ F (code: S0173)	/29/
Condenser for compressing ventilator KORA - 3 μ F (DC70S) (code: S0101)	/29/
Safety thermostat for 95 °C pump (DC75SE) (code: S0053)	/7/
Switching thermostat for 70 °C pump (DC75SE) (code: S0052)	/28/
Breaker	/33/, /37/



CAUTION - for boilers DC18S, DC22S, DC25S, DC15GS, DC20GS, DC22SX, DC25GS, DC30SE, DC30SX use the draught ventilator UCJ4C52 with rotation wheel around \varnothing 150 mm; for boilers DC32GS, DC40GS, DC32S, DC40SE, DC40SX use the draught ventilator UCJ4C52 with an open rotary wheel \varnothing 175 mm; for boiler DC50S, DC50SE use the draught ventilator UCJ4C52 with closed rotary wheel around \varnothing 175 mm; for boiler DC75SE use the draught ventilator UCJ4C82 with closed rotary wheel around \varnothing 200 mm.

Heatproof shaped piece (nozzle) replacement

- Material list:
1. Heatproof shaped piece
 2. sealing cord (3 pcs)
 3. boiler sealant (white)

Procedure: Remove or break up the old heatproof nozzle (further referred to as „nozzle“). Thoroughly clean the nozzle holder, which the nozzle was seated on, from tar and old sealant. Roll slim strands of boiler sealant. Place these continuously round the nozzle holder aperture in such a way which would prevent any penetration of secondary air underneath the nozzle later on. Take the new nozzle in your hand, stand in front of the boiler and position the nozzle in such a way that its recess (cut-out) is positioned

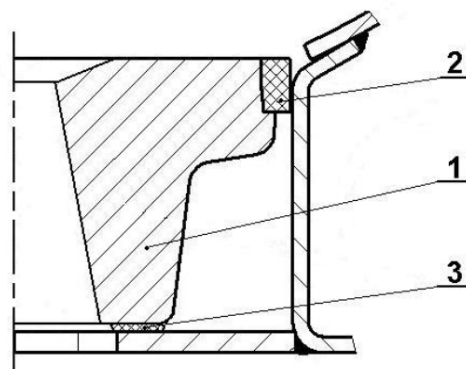

in a direction away from you and downwards (the recess is positioned inside the boiler; a mark on the nozzle - if present – is positioned backwards). The secondary air is brought to the nozzle from the rear section of the boiler. Place the nozzle on its holder and fully push towards the rear of boiler. Position it in such a way that free play between nozzle and holder is the same on both - the left and right side. Shape the sealing cords with a hammer so that their cross-section changes from square to

trapezoid shape. Then spread them along the sides and front of the nozzle and by gently tapping calk them evenly round its circumference so that they are level with the nozzle. Cover the sealing cord connections with a small amount of the boiler sealant.

Door sealing cord replacement

Procedure: Use a screwdriver to remove the old sealing cord and to clean the groove in which it was seated. Lightly shape the cord from a square into a trapeze cross-section using a hammer. Press the sealing cord along the door circumference (place the narrower base into the groove first) in such a way to ensure that the cord sticks well in the groove (if necessary use a little hammer). Position the lock's handle upwards, and with several gentle, careful taps of the door against the boiler, press the cord into the groove until the door can be closed smoothly. Fine-tune the position of the wheel that engages the lock's cam. This is the only procedure that can ensure good door seal!

Adjusting the door hinges and locks

The loading door and ash-pan door are firmly connected to the boiler drum by two sets of hinges. Each hinge consists of a nut, which is welded to the boiler drum, and a screw to which the door is connected by means of a pin. If you want to adjust the hinge settings, first take off the upper hood (control panel) and remove both pins. Then remove the door and slightly turn the screw with a right-hand thread, as necessary. By following these steps in reverse order, you can replace the door. The door lock consists of a lever with a handle and a cam which engages a wheel that is screwed into the boiler and secured by a nut preventing its turning.

36. Environmental protection

The ATMOS gasifying boilers comply with the most demanding environmental requirements and were awarded the "Environmentally friendly product" mark, in compliance with directive No. 13/2002 of the Ministry of Environment of the Czech Republic. The boilers are certified in compliance with the European standard EN 303-5 and they fall within class 3, 4 and 5.

Disposal of the boiler after expiration of its service life

It is necessary to provide an ENVIRONMENTALLY FRIENDLY DISPOSAL of the boiler's individual parts. Before disposal, clean all the flue cinder and place it in a refuse bin.

Then take the boiler to a collection point (collection yard) in accordance with the applicable legislation of the country and the EU and the Directive 2012/19/EU of the European Parliament and of the Council.

If there are no clear rules for handling used products in the country, take the boiler drum and hood to a scrap-metal collection site.

Take all the ceramic (fireclay) parts to an approved refuse site or to another designated place.



NOTE - In order to comply with the environmentally friendly operation requirements, it is prohibited to burn any other substances than specified for the boiler. Plastic bags, various plastic materials, paints, textiles, laminate are substances which should be particularly avoided but also avoid burning sawdust, sediment and coal dust.

GUARANTEE CONDITIONS

Hot-water boiler

1. If adhered to the product's use, operation and maintenance as described in the instruction manual, we guarantee that the product will maintain the characteristics as stipulated by the corresponding technical standards and terms for the duration of a guarantee period – of 24 months after the product's acquisition by the user, a maximum of 32 months after the manufacturer sells it to the sales representative. If the boiler is installed with a TV 60 °C (65/70/72/77 °C) thermoregulatory valve or Laddomat 22 in combination with the accumulation storage tanks (see attached schematics), the guarantee period for the boiler drum is extended from 24 to 36 months. The guarantee period for other parts remains unaffected.
2. If a defect not caused by the user, appears on the product during the guarantee period, the defect will be repaired free of charge.
3. The guarantee period is extended by the period of time for which has the product been under repair.
4. A claim to provide a guarantee period repair shall be made by the customer at the service company.
5. The guarantee claim is justified only in cases where the boiler installation was carried out by a person trained by the manufacturer and in compliance with valid standards and the instruction manual. A necessary condition for justifying a guarantee claim is possession of a legible and complete record identifying the company who installed the boiler. If the installation was not carried out in a professional manner, the subsequent costs are borne by the company that carried out the installation.
6. The purchaser was familiarised with the use and operation of the product – in a provable way.
7. A claim to provide an after-guarantee period repair shall be made by the customer at the service company, too. In this case, the customer bears the repair costs.
8. The user is obliged to adhere to instructions from the operation and maintenance manual. If the operation and maintenance manual is not adhered to, in cases of negligent or unprofessional handling, or burning prohibited substances, the guarantee expires and the repair costs are borne by the customer.
9. Boiler installation and operation must be in compliance with the instruction manual where the outgoing water temperature is in the 80 - 90 °C range and the temperature of water returning to boiler at least 65 °C in all its operation modes.
10. There is an obligation to have the boiler inspection carried out including its controls settings, structural elements and extraction system by an expert company at least once a year – confirmed in a warranty card
For boilers designated for the Czech Republic, Slovakia, Poland, Russia, Romania, Lithuania, Latvia and Hungary no guarantee conditions or insurance policies from outside these countries apply.



Guarantee and post-guarantee period repairs are carried out by:

- company representing **ATMOS** in the particular country for the particular region
- installation company that carried out the installation
- **Jaroslav Cankař a syn ATMOS, Velenského 487, 294 21 Bělá pod Bezdězem, Czech Republic, Telephone. +420 326 701 404**

BOILER INSTALLATION REPORT

Installation carried out by:

Company:
 Street: Town:
 Telephone: Country:

Ascertained data:

Chimney:	Flue-gas duct:
Dimensions:	Diameter:
Height:	Length:
Chimney draught:*	Number of elbow pieces:
Date of last inspection:	Waste gas temperature:*

Boiler connected with mixing valves and fittings (brief description of connection):

.....

Fuel:

Type:	Boiler functions and all regulations and safety
Size:	elements were inspected during the operation
Moisture content:*	start-up.

Person responsible for the inspection: Date:

Stamp: Customer's signature:
(Responsible person's signature)

* measured values

ANNUAL INSPECTIONS RECORDS

EN

Date stamp and signature	Date stamp and signature	Date stamp and signature	Date stamp and signature
Date stamp and signature	Date stamp and signature	Date stamp and signature	Date stamp and signature
Date stamp and signature	Date stamp and signature	Date stamp and signature	Date stamp and signature
Date stamp and signature	Date stamp and signature	Date stamp and signature	Date stamp and signature
Date stamp and signature	Date stamp and signature	Date stamp and signature	Date stamp and signature

RECORDS OF GUARANTEE PERIOD AND POST-GUARANTEE PERIOD REPAIRS

EN

Repair:
Repair:
Repair:
Repair:
Repair:
Repair:
Repair:

.....
repair carried out by, date

Repair:
Repair:
Repair:
Repair:
Repair:
Repair:
Repair:

.....
repair carried out by, date

Repair:
Repair:
Repair:
Repair:
Repair:
Repair:
Repair:

.....
repair carried out by, date

Repair:
Repair:
Repair:
Repair:
Repair:
Repair:
Repair:

.....
repair carried out by, date

Repair:
Repair:
Repair:
Repair:
Repair:
Repair:
Repair:

.....
repair carried out by, date

Informační list - Kotle na pevná paliva / Product sheet - Solid fuel boilers

Kotle teplovodní s ruční dodávkou paliva na dřevo / Hot-water boilers for wood with manual fuel supply

Název nebo ochranná známka dodavatele:
Supplier's name or trademark:



Jaroslav Cankař a syn ATMOS

ATMOS

Značka modelu	Třída energetické účinnosti	Jmenovitý tepelný výkon	Index energetické účinnosti	Sezonní energetická účinnost	Preferované palivo	Preventivní opatření
Model identifier	Energy efficiency class	Rated heat output	Energy Efficiency Index	Seasonal space heating energy efficiency	Preferred fuel	Specific precautions
		kW		%		
DC 15 E	A+	15	103	70	dřevo / wood	Provozní teplota kotle / Operation temperature of the boiler 80 °C - 90 °C Maximální provozní tlak / Maximal operation pressure 250 kPa Minimální teplota vratné vody / Minimal temperature of returning water into the boiler 65 °C
DC 18 S	A+	20	107	73	dřevo / wood	
DC 22 S	A+	22	116	79	dřevo / wood	
DC 22 SX	A+	22	107	73	dřevo / wood	
DC 25 S	A+	27	116	79	dřevo / wood	
DC 30 SX	A+	30	116	79	dřevo / wood	
DC 32 S	A+	35	115	78	dřevo / wood	
DC 30 SE	A+	30	112	76	dřevo / wood	
DC 40 SX	A+	40	115	78	dřevo / wood	
DC 15 GS	A+	15	118	80	dřevo / wood	
DC 20 GS	A+	20	117	80	dřevo / wood	
DC 25 GS	A+	25	115	78	dřevo / wood	
DC 32 GS	A+	32	116	79	dřevo / wood	
DC 40 GS	A+	40	115	78	dřevo / wood	
DC 40 SE	A+	40	110	75	dřevo / wood	
DC 50 S	A+	50	114	77	dřevo / wood	
DC 50 SE	A+	49	105	71	dřevo / wood	
DC 70 S	A+	70	114	78	dřevo / wood	
DC 75 SE	A+	75	107	73	dřevo / wood	